

# Professional Video Monitor

## Operating Instructions

Before operating the unit, please read this manual thoroughly and retain it for future reference.

**PVM-X550**

Software Version 1.0

**TRIMASTER EL 4K HDMI**

## Owner's Record

The model and serial numbers are located at the rear. Record these numbers in the spaces provided below. Refer to these numbers whenever you call upon your Sony dealer regarding this product.

Model No. \_\_\_\_\_  
Serial No. \_\_\_\_\_

### Important Safety Instructions

- Read these instructions.
- Keep these instructions.
- Heed all warnings.
- Follow all instructions.
- Do not use this apparatus near water.
- Clean only with dry cloth.
- Do not block any ventilation openings. Install in accordance with the manufacturer's instructions.
- Do not install near any heat sources such as radiators, heat registers, stoves, or other apparatus (including amplifiers) that produce heat.
- Do not defeat the safety purpose of the polarized or grounding-type plug. A polarized plug has two blades with one wider than the other. A grounding-type plug has two blades and a third grounding prong. The wide blade or the third prong are provided for your safety. If the provided plug does not fit into your outlet, consult an electrician for replacement of the obsolete outlet.
- Protect the power cord from being walked on or pinched particularly at plugs, convenience receptacles, and the point where they exit from the apparatus.
- Only use attachments/accessories specified by the manufacturer.
- Use only with the cart, stand, tripod, bracket, or table specified by the manufacturer, or sold with the apparatus.  When a cart is used, use caution when moving the cart/apparatus combination to avoid injury from tip-over.
- Unplug this apparatus during lightning storms or when unused for long periods of time.
- Refer all servicing to qualified service personnel. Servicing is required when the apparatus has been damaged in any way, such as power-supply cord or plug is damaged, liquid has been spilled or objects have fallen into the apparatus, the apparatus has been exposed to rain or moisture, does not operate normally, or has been dropped.

## WARNING

**To reduce the risk of fire or electric shock, do not expose this apparatus to rain or moisture.**

**To avoid electrical shock, do not open the cabinet. Refer servicing to qualified personnel only.**

**THIS APPARATUS MUST BE EARTHED.**

### WARNING

When installing the unit, incorporate a readily accessible disconnect device in the fixed wiring, or connect the power plug to an easily accessible socket-outlet near the unit. If a fault should occur during operation of the unit, operate the disconnect device to switch the power supply off, or disconnect the power plug.



This symbol is intended to alert the user to the presence of uninsulated “dangerous voltage” within the product’s enclosure that may be of sufficient magnitude to constitute a risk of electric shock to persons.



This symbol is intended to alert the user to the presence of important operating and maintenance (servicing) instructions in the literature accompanying the appliance.

### CAUTION

The apparatus shall not be exposed to dripping or splashing. No objects filled with liquids, such as vases, shall be placed on the apparatus.

### CAUTION

The unit is not disconnected from the AC power source (mains) as long as it is connected to the wall outlet, even if the unit itself has been turned off.

When installing the installation space must be secured in consideration of the ventilation and service operation.

- Do not block the ventilation slots, and vents of the fans.
- Leave a space around the unit for ventilation.
- Leave more than 40 cm of space in the rear of the unit to secure the operation area.

When the unit is installed on the desk or the like, leave at least 10 cm of space in the top side.

**WARNING:** THIS WARNING IS APPLICABLE FOR USA ONLY.

If used in USA, use the UL LISTED power cord specified below.

DO NOT USE ANY OTHER POWER CORD.

Plug Cap	Parallel blade with ground pin (NEMA 5-15P Configuration)
Cord	Type SJT or SVT, three 16 or 18 AWG wires
Length	Minimum 1.5 m (4 ft 11 in), Less than 2.5 m (8 ft 3 in)
Rating	Minimum 10A, 125V

Using this unit at a voltage other than 120V may require the use of a different line cord or attachment plug, or both. To reduce the risk of fire or electric shock, refer servicing to qualified service personnel.

**WARNING:** THIS WARNING IS APPLICABLE FOR OTHER COUNTRIES.

1. Use the approved Power Cord (3-core mains lead) / Appliance Connector / Plug with earthing-contacts that conforms to the safety regulations of each country if applicable.
2. Use the Power Cord (3-core mains lead) / Appliance Connector / Plug conforming to the proper ratings (Voltage, Ampere).

If you have questions on the use of the above Power Cord / Appliance Connector / Plug, please consult a qualified service personnel.

#### **For the customers in the U.S.A.**

This equipment has been tested and found to comply with the limits for a Class A digital device, pursuant to part 15 of the FCC Rules. These limits are designed to provide reasonable protection against harmful interference when the equipment is operated in a commercial environment. This equipment generates, uses, and can radiate radio frequency energy and, if not installed and used in accordance with the instruction manual, may cause harmful interference to radio communications. Operation of this equipment in a residential area is likely to cause harmful interference in which case the user will be required to correct the interference at his own expense.

You are cautioned that any changes or modifications not expressly approved in this manual could void your authority to operate this equipment.

All interface cables used to connect peripherals must be shielded in order to comply with the limits for a digital device pursuant to Subpart B of part 15 of FCC Rules.

This device complies with part 15 of the FCC Rules. Operation is subject to the following two conditions: (1) This device may not cause harmful interference, and (2) this device must accept any interference received, including interference that may cause undesired operation.

#### **For the customers in Canada**

CAN ICES-3 (A)/NMB-3(A)

#### **For the customers in Europe**

This product is intended for use in the following Electromagnetic Environment: E4 (controlled EMC environment, ex. TV studio).

This apparatus shall not be used in the residential area.

#### **For the customers in Europe, Australia and New Zealand**

#### **WARNING**

This equipment is compliant with Class A of CISPR 32. In a residential environment this equipment may cause radio interference.

#### **Disposal of Old Electrical & Electronic Equipment (Applicable in Republic of India)**



This symbol indicates that this product and its components, consumables, parts or spares thereof shall not be treated as household waste and may not be dropped in garbage bins. Product owners are advised to deposit their product at the nearest collection point for the recycling of electrical and electronic equipment. Your co-operation shall facilitate proper disposal & help prevent potential negative consequences/hazards to the environment and human health, which could otherwise be caused by inappropriate waste disposal including improper handling, accidental breakage, damage and/or improper recycling of e-waste. The recycling of materials will help to conserve natural resources. For more detailed information about recycling of this product, please contact your local civic office, your household waste disposal service provider or the store where you made the purchase. You may contact our company's toll free number in India for assistance.

Toll Free: 1800-103-7799

Visit: [www.sony.co.in](http://www.sony.co.in) for product recycling

#### **Reduction in the Use of Hazardous Substances in Electrical & Electronic Equipment (Applicable in Republic of India)**

This product and its components, consumables, parts or spares comply with the hazardous substances restriction of India's E-Waste (Management) Rules. The maximum allowable concentrations of the restricted substances are 0.1% by weight in homogenous materials for Lead, Mercury, Hexavalent Chromium, Polybrominated

Biphenyls (PBB) and Polybrominated Diphenyl Ethers (PBDE), and 0.01% by weight in homogenous materials for Cadmium, except for the exemptions specified in Schedule II of the aforesaid Rules.

**For the customers in the U.S.A.**

**SONY LIMITED WARRANTY** - Please visit <http://www.sony.com/psa/warranty> for important information and complete terms and conditions of Sony's limited warranty applicable to this product.

**For the customers in Canada**

**SONY LIMITED WARRANTY** - Please visit <http://www.sonybiz.ca/pro/lang/en/ca/article/resources-warranty-product-registration> for important information and complete terms and conditions of Sony's limited warranty applicable to this product.

**For the customers in Europe**

Sony Professional Solutions Europe - Standard Warranty and Exceptions on Standard Warranty. Please visit <http://www.pro.sony.eu/warranty> for important information and complete terms and conditions.

**For the customers in Korea**

**SONY LIMITED WARRANTY** - Please visit <http://bpeng.sony.co.kr/handler/BPAS-Start> for important information and complete terms and conditions of Sony's limited warranty applicable to this product.

**Consignes de sécurité importantes**

- Lisez ces instructions.
- Conservez ces instructions.
- Tenez compte de tous les avertissements.
- Suivez toutes les instructions.
- N'utilisez pas cet appareil à proximité d'eau.
- Nettoyez cet appareil uniquement avec un chiffon sec.
- Ne bloquez aucun orifice de ventilation. Installez cet appareil conformément aux instructions du fabricant.
- Ne l'installez pas à proximité de sources de chaleur comme des radiateurs, des registres de chaleur, des poêles ou d'autres appareils (y compris des amplificateurs) produisant de la chaleur.
- Ne désactivez pas le dispositif de sécurité de la fiche polarisée ou avec mise à la terre. Une fiche polarisée possède deux lames dont l'une est plus large que l'autre. Une fiche avec mise à la terre possède deux lames et une troisième broche de mise à la terre. La lame la plus large et la troisième broche sont fournies pour votre sécurité. Si la fiche fournie ne rentre pas dans votre prise de courant, consultez un électricien afin qu'il remplace la prise obsolète.

- Protégez le cordon d'alimentation afin que personne ne marche dessus et qu'il ne se coince pas, en particulier au niveau de la fiche, de la prise de courant et à l'endroit où il sort de l'appareil.
- N'utilisez que les fixations et accessoires indiqués par le fabricant.
- Utilisez l'appareil uniquement avec le chariot, le support, le trépied ou la table indiqué par le fabricant ou vendu avec l'appareil. Lorsque vous utilisez un chariot, faites attention lorsque vous déplacez le chariot et l'appareil ensemble afin d'éviter de vous blesser en cas de chute.
- Débranchez cet appareil en cas d'orage ou lorsqu'il n'est pas utilisé pendant de longues périodes.
- Faites appel à un technicien qualifié pour toute réparation/entretien. L'entretien/réparation est nécessaire lorsque l'appareil a été endommagé de quelque façon que ce soit, par exemple si le cordon ou la fiche d'alimentation a été endommagé, si du liquide a été renversé ou si des objets sont tombés dans l'appareil, si l'appareil a été exposé à la pluie ou à l'humidité, s'il ne fonctionne pas normalement ou s'il a subi une chute.



**AVERTISSEMENT**

**Afin de réduire les risques d'incendie ou d'électrocution, ne pas exposer cet appareil à la pluie ou à l'humidité.**

**Afin d'écartier tout risque d'électrocution, garder le coffret fermé. Ne confier l'entretien de l'appareil qu'à un personnel qualifié.**

**CET APPAREIL DOIT ÊTRE RELIÉ À LA TERRE.**

**AVERTISSEMENT**

Lors de l'installation de l'appareil, incorporer un dispositif de coupure dans le câblage fixe ou brancher la fiche d'alimentation dans une prise murale facilement accessible proche de l'appareil. En cas de problème lors du fonctionnement de l'appareil, enclencher le dispositif de coupure d'alimentation ou débrancher la fiche d'alimentation.





Ce symbole est destiné à avertir l'utilisateur de la présence d'une « tension dangereuse » non isolée dans l'enveloppe du produit, qui pourrait être suffisamment importante pour représenter un risque d'électrocution pour les personnes.



Ce symbole est destiné à avertir l'utilisateur de la présence d'instructions d'utilisation et de maintenance (entretien/réparation) importantes dans la documentation accompagnant l'appareil.

### ATTENTION

Eviter d'exposer l'appareil à un égouttement ou à des éclaboussures. Ne placer aucun objet rempli de liquide, comme un vase, sur l'appareil.

### ATTENTION

Cet appareil n'est pas déconnecté de la source d'alimentation secteur tant qu'il est raccordé à la prise murale, même si l'appareil lui-même a été mis hors tension.

### AVERTISSEMENT : CET AVERTISSEMENT

S'APPLIQUE AUX ÉTATS-UNIS UNIQUEMENT.

En cas d'utilisation aux États-Unis, utilisez le cordon d'alimentation RÉPERTORIÉ UL indiqué ci-dessous.

N'UTILISEZ AUCUN AUTRE CORDON D'ALIMENTATION.

Bouchon de fiche	Lame parallèle avec broche de terre (configuration NEMA 5-15P)
Cordon	Type SJT ou SVT, trois fils 16 ou 18 AWG
Longueur	Minimum 1,5 m (4 pieds 11 pouces), moins de 2,5 m (8 pieds 3 pouces)
Caractéristiques nominales	Minimum 10 A, 125 V

L'utilisation de cet appareil à une tension autre que 120 V peut nécessiter l'utilisation d'un type différent de cordon ou de fiche de fixation, ou les deux. Afin de réduire les risques d'incendie ou d'électrocution, faites appel à un technicien qualifié pour toute réparation/entretien.

### AVERTISSEMENT : CET AVERTISSEMENT

S'APPLIQUE AUX AUTRES PAYS.

1. Utilisez un cordon d'alimentation (câble secteur à 3 fils)/fiche femelle/fiche mâle avec des contacts de mise à la terre conformes à la réglementation de sécurité locale applicable.
2. Utilisez un cordon d'alimentation (câble secteur à 3 fils)/fiche femelle/fiche mâle avec des caractéristiques nominales (tension, ampérage) appropriées.

Pour toute question sur l'utilisation du cordon d'alimentation/fiche femelle/fiche mâle ci-dessus, consultez un technicien du service après-vente qualifié.

### Pour les clients au Canada

CAN ICES-3 (A)/NMB-3(A)

### Pour les clients en Europe

Ce produit est prévu pour être utilisé dans l'environnement électromagnétique suivant: E4 (environnement EMC contrôlé, ex. studio de télévision).

Ne pas utiliser cet appareil dans une zone résidentielle.

### Pour les clients en Europe, Australie et Nouvelle-Zélande

### AVERTISSEMENT

Cet appareil est conforme à la Classe A de CISPR 32. Dans un environnement domestique, cet appareil peut provoquer des interférences radio.

### Pour les clients au Canada

**GARANTIE LIMITÉE DE SONY** - Rendez-vous sur <http://www.sonybiz.ca/pro/lang/en/ca/article/resources-warranty-product-registration> pour obtenir les informations importantes et l'ensemble des termes et conditions de la garantie limitée de Sony applicable à ce produit.

### WARNUNG

**Um die Gefahr von Bränden oder elektrischen Schlägen zu verringern, darf dieses Gerät nicht Regen oder Feuchtigkeit ausgesetzt werden.**

**Um einen elektrischen Schlag zu vermeiden, darf das Gehäuse nicht geöffnet werden. Überlassen Sie Wartungsarbeiten stets nur qualifiziertem Fachpersonal.**

**DIESES GERÄT MUSS GEERDET WERDEN.**

### WARNUNG

Beim Einbau des Geräts ist daher im Festkabel ein leicht zugänglicher Unterbrecher einzufügen, oder der Netzstecker muss mit einer in der Nähe des Geräts befindlichen, leicht zugänglichen Wandsteckdose verbunden werden. Wenn während des Betriebs eine Funktionsstörung auftritt, ist der Unterbrecher zu betätigen bzw. der Netzstecker abzuziehen, damit die Stromversorgung zum Gerät unterbrochen wird.

## VORSICHT

Das Gerät ist nicht tropf- und spritzwassergeschützt. Es dürfen keine mit Flüssigkeiten gefüllten Gegenstände, z. B. Vasen, darauf abgestellt werden.

## VORSICHT

Solange das Netzkabel an eine Netzsteckdose angeschlossen ist, bleibt das Gerät auch im ausgeschalteten Zustand mit dem Stromnetz verbunden.

## WARNUNG

1. Verwenden Sie ein geprüftes Netzkabel (3-adriges Stromkabel)/einen geprüften Geräteanschluss/einen geprüften Stecker mit Schutzkontakten entsprechend den Sicherheitsvorschriften, die im betreffenden Land gelten.
2. Verwenden Sie ein Netzkabel (3-adriges Stromkabel)/einen Geräteanschluss/einen Stecker mit den geeigneten Anschlusswerten (Volt, Ampere).

Wenn Sie Fragen zur Verwendung von Netzkabel/ Geräteanschluss/Stecker haben, wenden Sie sich bitte an qualifiziertes Kundendienstpersonal.

## Für Kunden in Europa

Für die folgende elektromagnetische Umgebung: E4 (kontrollierter EMV-Bereich, z.B. Fernsehstudio).

Dieser Apparat darf nicht im Wohnbereich verwendet werden.

## Für Kunden in Europa, Australien und Neuseeland

## WARNUNG

Dieses Gerät entspricht CISPR 32, Klasse A. Dieses Gerät kann im Wohnbereich Funkstörungen verursachen.

## For kundene i Norge

Dette utstyret kan kobles til et IT-strømfordelingssystem.

Apparatet må tilkoples jordet stikkontakt

## Suomessa asuville asiakkaille

Laite on liitettävä suojamaadoituskoskettimilla varustettuun pistorasiaan

## För kunderna i Sverige

Apparaten skall anslutas till jordat uttag

## For kunder i Danmark

Apparatets stikprop skal tilsluttes en stikkontakt med jord, som giver forbindelse til stikproppens jord.

## A급 기기(업무용 방송통신기자재)

이 기기는 업무용(A급) 전자파적합기기로서 판매자 또는 사용자는 이 점을 주의하시기 바라며, 가정 외의 지역에서 사용하는 것을 목적으로 합니다.

주소: 서울시 영등포구 영등포동 2가 28-130 가야벤처빌딩 2층 소니코리아  
전화번호: 02-782-3560  
팩스번호: 02-782-4466

콜센터: 02-1588-7313

웹사이트 주소: <http://bpeng.sony.co.kr/>  
<http://bp.sony.co.kr/>

## 警告使用者:

這是甲類的資訊產品，在居住的環境中使用時，可能會造成射頻干擾，在這種情況下，使用者會被要求採取某些適當的對策。

## ПРЕДУПРЕЖДЕНИЕ

**Для снижения риска возгорания и поражения электрическим током не допускайте воздействия на аппарат влаги и сырости.**

**Чтобы исключить риск поражения электрическим током, не вскрывайте корпус. Обслуживание аппарата должны выполнять только квалифицированные специалисты.**

**ДАННОЕ УСТРОЙСТВО ДОЛЖНО БЫТЬ ЗАЗЕМЛЕНО.**

## ПРЕДУПРЕЖДЕНИЕ

При установке устройства используйте легкодоступный прерыватель питания с фиксированной проводкой или подключите провод питания к легкодоступной настенной розетка, расположенной рядом с устройством. Если в процессе эксплуатации блока возникнет неисправность, с помощью прерывателя отключите питание, или отсоедините провод питания.

## ВНИМАНИЕ

Аппарат не должен подвергаться воздействию капель или брызг. Запрещается помещать какие-либо наполненные жидкостью предметы, например, вазы, на аппарат.

## ВНИМАНИЕ

Устройство не считается отключенным от источника питания переменного тока (сети), пока оно остается подключенным к настенной розетке, несмотря на то, что само устройство может быть выключено.

При установке необходимо обеспечить монтажное пространство, достаточное для вентиляции и обслуживания.

- Не закрывайте вентиляционные щели, а также вентиляционные отверстия вентиляторов.



- Оставьте вокруг устройства свободное пространство для вентиляции.
- Оставьте сзади устройства свободное пространство шириной не менее 40 см, чтобы обеспечить рабочую зону.

При установке на рабочем столе или в другом подобном месте оставьте над устройством свободное пространство высотой не менее 10 см.

### **ПРЕДУПРЕЖДЕНИЕ**

1. Используйте разрешенные к применению шнуры питания (с 3-жильным силовым проводом) / разъем для подключения бытовых приборов / штепсельную вилку с заземляющими контактами, соответствующие действующим нормам техники безопасности каждой отдельной страны.
2. Используйте шнур питания (с 3-жильным силовым проводом) / разъем для подключения бытовых приборов / штепсельную вилку, соответствующие допустимым номинальным характеристикам (напряжение, сила тока).

В случае вопросов относительно использования упомянутых выше шнура питания / разъема для подключения бытовых приборов / штепсельной вилки, пожалуйста, обращайтесь к квалифицированным специалистам по сервисному обслуживанию.

Данный аппарат не следует использовать в жилой зоне.

### **Для клиентов в России и Белоруссии**

Это видеомонитор для производства видео.

Название продукта: Профессиональный Видеомонитор

Сони Корпорейшн  
1-7-1, Конан, Минато-ку, Токио, 108-0075, Япония

Импортер на территории стран Таможенного союза АО «Сони Электроникс», Россия, 123103, Москва, Карамышевский проезд, 6

Сделано в ЯПОНИИ

Год производства: см. паспортную табличку на изделии.

Пример: (2013-01)  
2013: означает год  
01: означает месяц

Номинальные значения: см. стр. 41 данного руководства.

Размеры, вес: см. стр. 51 данного руководства.

## **ЕСКЕРТУ**

**Өрт шығу немесе ток соғу қаупін азайту үшін бұл құрылғыны жаңбырдың астында немесе ылғалды жерде қалдырмаңыз.**

**Ток соғуды болдырмау үшін құрылғының корпусын ашаңыз. Жөндеу жұмыстарын білікті мамандар ғана орындауы тиіс.**

## **БҰЛ ҚҰРЫЛҒЫНЫ ЖЕРГЕ ҚОСУ КЕРЕК.**

### **ЕСКЕРТУ**

Құрылғыны орнатқан кезде, бекітілген электр схемасына оңай қол жеткізуге болатын ажыратқышты қосыңыз немесе штепсельді құрылғының жанындағы оңай қол жеткізуге болатын желілік розеткаға қосыңыз. Құрылғыны пайдалану кезінде ақау пайда болса, қуат көзін ажырату үшін ажыратқышты пайдаланыңыз немесе штепсельді ажыратыңыз.

### **АБАЙЛАҢЫЗ**

Құрылғыны сұйықтық тамшылайтын немесе шашырайтын жерге қоймаңыз. Сауыт сияқты ішіне сұйықтық құйылған ыдыстарды құрылғының үстіне қоюға болмайды.

### **АБАЙЛАҢЫЗ**

Қабырғадағы розеткаға қосулы тұрғанда, құрылғының өзі өшірілсе де, құрылғы айнымалы ток қуат көзінен ажыратылмайды.

Орнату кезінде орнату аумағы желдету және қызмет көрсетуді есепке ала отырып көзделуі тиіс.

- Желдету тесіктерін және желдеткіш саңылауларын бөгемеңіз.
- Құрылғы айналасында желдету үшін бос аралық қалдырыңыз.
- Жұмыс ауқымын қамтамасыз ету үшін құрылғының артқы жағында 40 см артық аралықты қалдырыңыз.

Құрылғы үстел немесе оған ұқсас бетке орнатылғанда, жоғарғы жағынан 10 см аралықты қалдырыңыз.

## ЕСКЕРТУ

1. Мүмкін болса, мақұлданған және әр елдің қауіпсіздік ережелеріне сай Қуат сымын (3-өзекті желі сымы) / Құрылғы коннекторын / Жерге тұйықтау түйіспелері бар айыр штепсельді пайдаланыңыз.
2. Тиісті көрсеткіштерге (Кернеу, ампер) сай Қуат сымын (3-өзекті желі сымы) / Құрылғы коннекторын / Айыр штепсельді пайдаланыңыз.

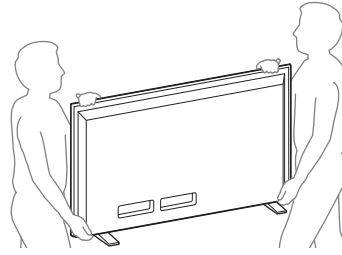

Егер жоғарыдағы Қуат сымын / Құрылғы коннекторын / Айыр штепсельді пайдалану туралы сұрақтарыңыз болса, білікті маманға жүгінізіз.

Бұл құрылғыны тұрғын аумақта пайдалануға болмайды.

## Қазақстандағы тұтынушыларға арналған

Бұл – бейне өндірісіне арналған сурет монитормы.

Өнімнің атауы: Кәсіптік Бейнемонитор

Дайындаушы: Сони Корпорейшн

Мекен-жайы: 1-7-1 Конан, Минато-ку, Токио 108-0075, Жапония

Кеден одағы жеріндегі шетелден әкелуші  
«Сони Электроникс» АҚ, Ресей, 123103, Мәскеу,  
Карамышевский өтпе көшесі, 6

Жапонияда жасалған

Өндірілген жылы: Өнімдегі атау тақтайшасын  
қараңыз.

Мысалы, (2013-01)

2013: жылды білдіреді

01: айды білдіреді

Номиналды мәндер: Осы нұсқаулықтың 41-бетін  
қараңыз.

Өлшемдері, Салмағы: Осы нұсқаулықтың 51-бетін  
қараңыз.

## Інформація для споживачів в Україні.

Обладнання відповідає вимогам:

- Технічного регламенту обмеження використання деяких небезпечних речовин в електричному та електронному обладнанні (постанова КМУ від 03/12/2008 № 1057).

## Türkiye'deki müşteriler için AEEE Yönetmeliğine Uygundur

### Caution

- This unit is heavy. Make sure to unpack and move the unit with two or more people.
- Firmly grip the bottom of this unit as shown below.



---

# Table of Contents

<b>Precaution .....</b>	<b>10</b>
On Safety .....	10
On Installation .....	10
Connecting to Other Devices .....	10
Handling the Screen .....	10
On Burn-in .....	10
On a Long Period of Use .....	11
On High Brightness Display .....	11
On the Surface of the Unit .....	11
On Long Periods of Continuous Use .....	11
Handling and Maintenance of the Screen .....	11
On Dew Condensation .....	12
On Repacking .....	12
Disposal of the Unit .....	12
On Fan Error .....	12
<b>Location and Function of Parts and</b>	
<b>Controls .....</b>	<b>13</b>
Front Panel/Side Panel .....	13
Input Signals and Adjustable/Setting Items .....	16
Quad View Functions and Adjustable/Setting	
Items.....	17
Rear Panel .....	18
<b>Attaching the Monitor Stand .....</b>	<b>19</b>
<b>Connecting the AC Power Cord .....</b>	<b>20</b>
<b>Connecting the HDMI cable .....</b>	<b>20</b>
<b>Using the Menu .....</b>	<b>21</b>
<b>Switching the Input Signal .....</b>	<b>22</b>
<b>Protection of the Setting Values .....</b>	<b>22</b>
<b>Adjustment Using the Menus .....</b>	<b>23</b>
Items .....	23
Adjusting and Changing the Settings .....	23
[Status] menu .....	23
[User Preset Setting] menu .....	24
[Color Temp.] menu .....	25
[User Configuration] menu .....	26
[Serial Remote] menu .....	38
[Security] menu .....	39
<b>Connecting the SDI Signals .....</b>	<b>39</b>
<b>Troubleshooting .....</b>	<b>40</b>
<b>Specifications .....</b>	<b>41</b>
Available Signal Formats.....	42
<b>Dimensions .....</b>	<b>51</b>

The terms HDMI and HDMI High-Definition Multimedia Interface, and the HDMI Logo are trademarks or registered trademarks of HDMI Licensing LLC in the United States and other countries.

---

## Precaution

---

### On Safety

- Operate the unit only with a power source as specified in the “Specifications” section.
- A nameplate indicating operating voltage, etc., is located on the rear panel.
- Should any solid object or liquid fall into the cabinet, unplug the unit and have it checked by qualified personnel before operating it any further.
- Do not drop or place heavy objects on the power cord. If the power cord is damaged, turn off the power immediately. It is dangerous to use the unit with a damaged power cord.
- Unplug the unit from the wall outlet if it is not to be used for several days or more.
- Disconnect the power cord from the AC outlet by grasping the plug, not by pulling the cord.
- The socket-outlet shall be installed near the equipment and shall be easily accessible.

---

### On Installation

- Allow adequate air circulation to prevent internal heat build-up.  
Do not place the unit on surfaces (rugs, blankets, etc.) or near materials (curtains, draperies) that may block the ventilation holes.
- Do not install the unit in a location near heat sources such as radiators or air ducts, or in a place subject to direct sunlight, excessive dust, mechanical vibration or shock.

When installing the installation space must be secured in consideration of the ventilation and service operation.

- Do not block the ventilation slots, and vents of the fans.
- Leave a space around the unit for ventilation.
- Leave more than 40 cm of space in the rear of the unit to secure the operation area.

When the unit is installed on the desk or the like, leave at least 10 cm of space in the top side.

---

### Connecting to Other Devices

When connecting this unit to other devices, turn off this unit and the other devices beforehand. Connecting while turned on may cause a malfunction to this unit and the other devices.

---

## Handling the Screen

- The OLED panel fitted to this unit is manufactured with high precision technology, giving a functioning pixel ratio of at least 99.99%. Thus a very small proportion of pixels may be “stuck”, either always off (black), always on (red, green, or blue), or flashing. In addition, over a long period of use, because of the physical characteristics of the organic light-emitting diode, such “stuck” pixels may appear spontaneously. These problems are not a malfunction.
- Do not leave the screen facing the sun as it can damage the screen. Take care when you place the unit by a window.
- Do not push or scratch the monitor’s screen. Do not place a heavy object on the monitor’s screen. This may cause the screen to lose uniformity.
- The screen and the cabinet become warm during operation. This is not a malfunction.
- An afterimage may be displayed depending on the input image. This is not a malfunction.

---

### On Burn-in

Due to the characteristics of the material used in the OLED panel, permanent burn-in or reduction in brightness may occur.

These problems are not a malfunction.

#### Images that may cause burn-in

- Still images in the HDR display
- Masked images with aspect ratios other than 16:9
- Color bars or images that remain static for a long time
- Character or message displays that indicate settings or the operating state
- On-screen displays such as center markers or area markers
- Images with a frame (including Multi-View displays)

*For details on the HDR (High Dynamic Range) display, see page 29.*

#### To reduce the risk of burn-in

- Turn off the character and marker displays  
Press the MENU button to turn off the character displays. To turn off the character or marker displays of the connected equipment, operate the connected equipment accordingly. For details, refer to the operation manual of the connected equipment.
- Do not display static images that contain high brightness display, time codes, markers, or logos for extended periods. Consider applying a display method with low level signals of 100% or less.
- Do not display the images with a frame for a long time. Also, consider removing the frame during the Multi-View display, or displaying the signal level of the frame area by about 50% of the display area.

- Reduce the brightness  
Reduce the brightness as much as possible or reduce the input signal level when you do not use the display.
- Turn off the power when not in use  
Turn off the power if the monitor is not to be used for a prolonged period of time.

### Screen saver

This product has a built-in screen saver function to reduce burn-in. When an almost still image is displayed for more than 10 minutes, the screen saver starts automatically and the brightness of the screen decreases.

### Panel Calibration

This product has a Panel Calibration function to adjust the uniformity of the screen.

It is recommended to perform Panel Calibration once a week. Perform Panel Calibration in the range of the recommended environmental temperature (20 °C to 30 °C (68 °F to 86 °F)).

For details, see [Panel Calibration] (page 27).

Perform Panel Calibration when the CALIBR. indicator lights up in yellow.

Images cannot be displayed when performing Panel Calibration.

---

## On a Long Period of Use

Due to an OLED's panel structure and characteristics of materials in its design, displaying static images for extended periods, or using the unit repeatedly in a high temperature/high humidity environments may cause image smearing, burn-in, areas of which brightness is permanently changed, lines, or a decrease in overall brightness.

In particular, continually displaying an image smaller than the monitor screen, such as displaying an image in a different aspect ratio or displaying an image with a frame, may expedite the above issues.

Avoid displaying a still image for an extended period, or using the unit repeatedly in a high temperature/high humidity environment such as an airtight room, or around the outlet of an air conditioner.

To prevent any of the above issues, we recommend reducing brightness slightly, and to turn off the power whenever the unit is not in use.

---

## On High Brightness Display

- Using the unit with the high brightness display for extended periods may cause eyestrain or reduction of eyesight. Be sure to take an occasional break when using.

- Follow RECOMMENDATION ITU-R BT.1702 "Guidance for the reduction of photosensitive epileptic seizures caused by television" or other guidelines when using.
- In the HDR display, the display surface may emit heat when high brightness images are output. Do not touch the surface.
- When [2.4(HDR)], [S-Log3(HDR)], [S-Log2(HDR)], [SMPTE ST 2084(HDR)], [HLG SG 1.2(HDR)], or [HLG SG Variable(HDR)] is selected for [EOTF] in the [Input Setting] menu, images are displayed in HDR (High Dynamic Range).  
In this manual, this status is described as "HDR display."

*For details on the HDR (High Dynamic Range) display, see page 29.*

---

## On the Surface of the Unit

The surface of the unit becomes extremely hot. Do not touch the surface with your hand or body during power distribution. It may cause a burn.

---

## On Long Periods of Continuous Use

Using this unit for extended periods may cause eyestrain or reduction of eyesight.

As soon as you feel physical discomfort or pain, stop using this unit immediately and take a break.

If the physical discomfort or pain remains even after taking a break, consult a physician.

---

## Handling and Maintenance of the Screen

The surface of the screen is specially coated to reduce image reflection. Make sure to observe the following points as improper maintenance procedures may impair the screen's performance. In addition, the screen is vulnerable to damage. Do not scratch or knock against it using a hard object.

- Be sure to disconnect the AC power cord from the AC outlet before performing maintenance.
- The surface of the screen is specially coated. Do not attach adhesive objects, such as stickers, on it.
- The surface of the screen is specially coated. Do not touch the screen directly.
- Wipe the screen surface gently with the supplied cleaning cloth or a soft dry cloth to remove dirt.
- Stubborn stains may be removed with the supplied cleaning cloth, or a soft cloth slightly dampened with a mild detergent solution.

- The screen may become scratched if the cleaning cloth is dusty.
- Never use strong solvents such as alcohol, benzene, thinner, acidic or alkaline detergent, detergent with abrasives, or chemical wipe as these may damage the screen.
- Use a blower to remove dust from the screen surface.

---

## On Dew Condensation

If the unit is suddenly taken from a cold to a warm location, or if ambient temperature suddenly rises, moisture may form on the outer surface of the unit and/or inside of the unit. This is known as condensation. If condensation occurs, turn off the unit and wait until the condensation clears before operating the unit. Operating the unit while condensation is present may damage the unit.

---

## On Repacking

Do not throw away the carton and packing materials. They make an ideal container which to transport the unit.

---

## Disposal of the Unit

- Do not dispose of the unit with general waste. Do not include the monitor with household waste.
- When you dispose of the monitor, you must obey the law in the relative area or country.

---

## On Fan Error

The unit has a built in fan for cooling. When the fan stops and the  (Power) indicator blinks in red, turn off the power and contact an authorized Sony dealer.

# Location and Function of Parts and Controls

## Front Panel/Side Panel

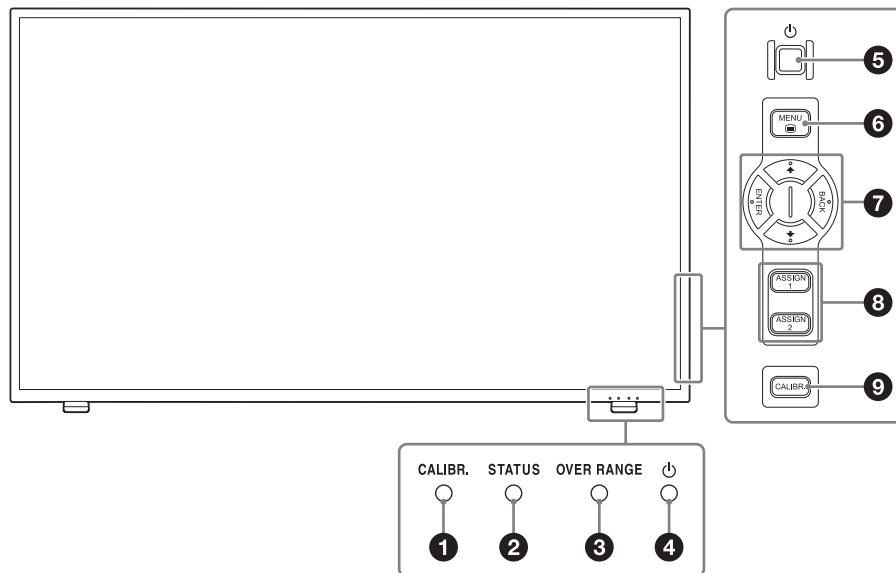

### 1 CALIBR. (Calibration) indicator

Lights up in yellow when performing Panel Calibration is necessary. [Recommend Calibration] is also displayed. Blinks in yellow when performing Panel Calibration. When Panel Calibration is finished, the CALIBR. indicator will be turned off and the ⏻ (Power) indicator will light up in red.

If Panel Calibration is not finished normally, the indicator lights in yellow the next time the unit is started. At this time, the following message is displayed. [Recommend Re-calibration]: Previous Panel Calibration is not completed successfully. Execute Panel Calibration again.

#### Note

If the yellow light persists after performing Panel Calibration more than a few times, contact an authorized Sony dealer.

### 2 STATUS indicator

Slowly flashes in yellow when the screen saver starts up, and quickly flashes in yellow when a warning during startup occurs.

Lights up in blue during HDR display. Slowly flashes in blue when the screen saver displaying in HDR starts up, and quickly flashes in blue when a warning during startup occurs.

*For details on the HDR (High Dynamic Range) display, see page 29.*

### 3 OVER RANGE indicator

Lights in amber when ABL (Automatic Brightness Limiter) starts.

### 4 ⏻ (Power) indicator

Pressing the ⏻ (Power) switch on the side turns on the power.

When the unit turns on, the unit starts up with the indicator flashing in green. When the unit is operating, the indicator lights in green.

The indicator turns off when the power is off.

The indicator lights up in red during the sleep mode.

### 5 ⏻ (Power) switch

When the unit is turned off, press the switch to turn it on. Press the switch again to turn off the unit.

### 6 MENU button

When the on-screen menu is not displayed, press the button to display the menu. Press again to clear the menu.

### 7 Menu operation buttons

#### ↑/↓ buttons

When the menu is displayed, press the buttons to select a menu item or setting value.

#### ENTER button

When the menu is displayed, press the button to confirm a menu item or setting value.

If the menu is not displayed and the button is pressed, the signal format is displayed on the screen.

### BACK button

When the menu is displayed, press the button to reset the value of an item to the previous value (except some items).

### 8 ASSIGN 1/ASSIGN 2 buttons

Set on or off for the assigned function.

The factory default settings are the following.

**ASSIGN 1:** [In.Select/In.Setting]

**ASSIGN 2:** [Native Scan]

Each function can be assigned at [Assign Button Setting] (page 33) of the [User Configuration] menu.

Press and hold the ASSIGN 1/ASSIGN 2 button to display the [Assign Button Setting] menu and make changes to the setting.

### 9 CALIBR. (Calibration) button

Press the button to perform Panel Calibration.

Press the button to display the confirmation screen and press the CALIBR. button again or select [Confirm] and press the ENTER button to perform Panel Calibration. Press the MENU button or select [Cancel] and press the ENTER button to cancel Panel Calibration while the confirmation screen is displayed.

For details on the Panel Calibration function, see [Panel Calibration] (page 27).

## About error/warning signals of the indicator

While the unit is in use, the  (Power) indicator or OVER RANGE indicator of the front panel may show error or warning signals.

If an error display appears, refer to Sony qualified service personnel.

### Error display

OVER RANGE indicator	Power indicator	Symptom
–	Flashes in red (every second)	Power abnormality, circuit board abnormality, sensor abnormality, environmental temperature abnormality, panel abnormality
–	Flashes in red (every two seconds)	Fan abnormality

## Warning display

OVER RANGE indicator	Power indicator	Symptom
Flashes in amber (every second) <sup>1)</sup> (every 2 seconds) <sup>2)</sup>	–	Decreases the brightness to protect the panel from overheating
Lights in amber	–	ABL starts

- 1) When using in the HDR display, regardless of the input signal, the screen brightness may decrease when the protective function for the OLED panel activates. To avoid the brightness decrease due to the protection function, it is recommended to keep the temperature of the peripheral environment of the unit around 25 °C.
- 2) When using in the HDR display, if a high level signal is continuously displayed on the same part, the brightness of the high signal level part may decrease to lower the temperature of the OLED panel. To avoid decreasing brightness from this protection function, do not allow a bright signal to be displayed continuously on the same area.

For details on the HDR (High Dynamic Range) display, see page 29.

## About operations using the Sony monitor control unit

When the optional BKM-16R is connected, the following operations are available with the buttons of the controller.

### Menu operation buttons

Button	Operations
MENU button	When the on-screen menu is not displayed, press the button to display the menu. When the top of the menu screen is displayed, press the button to clear the menu. Press the button while adjusting the menu and the value of the item returns to the previous value.
ENTER button	When the menu is displayed, press the button to confirm a menu item or setting value. Press the button while the menu screen is not displayed and the functions which are assigned to the function buttons and numeric buttons are displayed. Press again to clear it.  However, the following operation is not available. <ul style="list-style-type: none"> <li>• Displaying the signal format</li> </ul>
UP button DOWN button	When the menu is displayed, press the button to select a menu item or setting value.



## Power button

Button	Operations
MONITOR   / ⏻ switch	Switches the operating mode of the monitor. Press the button for the sleep mode when the monitor is in the operating mode. The power indicator on the front panel lights in red. Press the button for the operating mode when the monitor is in the sleep mode.

## Rotary encoder/MANUAL buttons

Knob	Operations
CONTRAST knob	Adjusts the picture contrast.
BRIGHT knob	Adjusts the picture brightness.
CHROMA knob	Adjusts the color intensity.
PHASE knob	Available only in the color temperature adjusting menu. No other operations are available.

Button	Operations
CONTRAST MANUAL button	Press the button to adjust contrast manually.
BRIGHT MANUAL button	Press the button to adjust brightness manually.
CHROMA MANUAL button	Press the button to adjust color intensity manually.
PHASE MANUAL button	Available only in the color temperature adjusting menu. No other operations are available.

## Function buttons

Button	Operations
F1 to F16 button	Turns on or off functions assigned to the function buttons on the controller. The following functions are available. For details on each function, see “About functions assigned to the ASSIGN 1/2 buttons” (page 33). [Mono], [Blue Only], [Native Scan], [R Off], [G Off], [B Off], [Character Off] <sup>1)</sup> , [Aperture] (selecting the manually adjusted setting in [Aperture]), [Marker], [Aspect Marker], [Area Marker1], [Area Marker2], [Center Marker], [Aspect Marker-Line], [Aspect Blanking-Half], [Aspect Blanking-Black] 1) You can hide the menu during the picture control. Push again restore the original menu.

## Numeric buttons

Button	Operations
0 button	Press the button to perform Panel Calibration. Press the button to display the confirmation screen and press the 0 button again or select [Confirm] and press the ENTER button to perform Panel Calibration. Press the MENU button or select [Cancel] and press the ENTER button to cancel Panel Calibration while the confirmation screen is displayed. For details on the Panel Calibration function, see [Panel Calibration] (page 27).
1 to 9 button	Turns on or off functions assigned to the numeric buttons from 1 to 9 on the controller. The factory default settings are following: 1 button: [SDI1 4K] 2 button: [SDI1 2K] 3 button: [SDI2 4K] 4 button: [SDI2 2K] 5 button: [HDMI] 6 button: [Native Scan] 7 button: [Internal Signal] 8 button: [User Preset1] 9 button: [User Preset2] Each function can be assigned at [Function/Numeric Button Setting] (page 38) of the [Serial Remote] menu.
Ent button	Operates similar to the ENTER button on the controller.

### Note

You can connect up to 3 BKM-16R units to the PVM-X550.

## Input Signals and Adjustable/Setting Items

Item	Input signal							
	SDI 1/2 4K			SDI 1/2 2K			HDMI	
	YCbCr	RGB	XYZ	YCbCr	RGB	XYZ	YCbCr	RGB
APERTURE	○	○	×	○	○	×	○	○
CHROMA <sup>1)</sup>	○	○	×	○	○	×	○	○
BRIGHT	○	○	○	○	○	○	○	○
CONTRAST	○	○	○	○	○	○	○	○
User Preset	○	○	○	○	○	○	○	○
Color Temp.	○	○	○	○	○	○	○	○
Manual Adjustment (Color Temp.)	○	○	○	○	○	○	○	○
Flicker Free <sup>2)</sup>	○	○	○	○	○	○	○	○
Screen Saver <sup>2)</sup>	○	○	○	○	○	○	○	○
RGB Range	×	○	×	×	○	×	×	○
YCC Range	×	×	×	×	×	×	○	×
Color Space	○	○	×	○	○	×	○	○
EOTF	○	○	×	○	○	×	○	○
Transfer Matrix	○	×	×	○	×	×	○	○
Internal Signal	○	○	×	○	○	×	○	○
Internal Signal Pattern	○	○	×	○	○	×	○	○
Mono <sup>3)</sup>	○	○	○	○	○	○	○	○
Blue Only	○	○	○	○	○	○	○	○
R Off	○	○	○	○	○	○	○	○
G Off	○	○	○	○	○	○	○	○
B Off	○	○	○	○	○	○	○	○
Character Off	○	○	○	○	○	○	○	○
Native Scan	○	○	○	○	○	○	○	○
1080I/PsF <sup>4)</sup>	×	×	×	○	○	○	×	×
Area and Aspect Marker	○	○	○	○	○	○	○	○
Gamut Marker <sup>5)</sup>	○	○	×	○	○	×	○	○
Input Setting	○	○	○	○	○	○	○	○

○ : Adjustable/can be set

× : Not adjustable/cannot be set

- 1) When the EOTF is set to [S-Log3(HDR)], [S-Log2(HDR)], [SMPTE ST 2084(HDR)], [HLG SG 1.2(HDR)] or [HLG SG Variable(HDR)], this does not function.
- 2) Available only during SDR (Standard Dynamic Range) display.
- 3) When the RGB signal is input, the brightness signal based on the transfer matrix selected in [Transfer Matrix] is displayed.
- 4) The setting is available when 50I, 59.94I, 60I, 25PsF, 29.97PsF, or 30PsF signals are input in the SDI 2K input.
- 5) The setting is available while [ITU-R BT.2020] is selected for color space.

## Quad View Functions and Adjustable/Setting Items

Item	Function	
	Quad View <sup>2)</sup>	
	Common setting for four views	Individual setting for each view
APERTURE	○	○ <sup>3)</sup>
CHROMA <sup>1)</sup>	○	○ <sup>3)</sup>
BRIGHT	○	○ <sup>3)</sup>
CONTRAST	○	○ <sup>3)</sup>
User Preset	○	○
Color Temp.	○	○ <sup>3)</sup>
Manual Adjustment (Color Temp.)	○	○ <sup>3)</sup>
Flicker Free	○ <sup>4)</sup>	×
Screen Saver	○	×
RGB Range	○	○ <sup>3)</sup>
YCC Range	○	○ <sup>3)</sup>
Color Space	○	○ <sup>3)</sup>
EOTF	○	○ <sup>3)</sup>
Transfer Matrix	○	○ <sup>3)</sup>
Internal Signal	×	×
Internal Signal Pattern	×	×
Mono	○	×
Blue Only	○	×
R Off	○	×
G Off	○	×
B Off	○	×
Character Off	○	×
Native Scan	×	×
1080I/PsF	○	×
Area and Aspect Marker	×	×
Gamut Marker	○	×
Input Setting	×	○

○ : Adjustable/can be set

× : Not adjustable/cannot be set

- 1) When the EOTF is set to [S-Log3(HDR)], [S-Log2(HDR)], [SMPTE ST 2084(HDR)], [HLG SG 1.2(HDR)] or [HLG SG Variable(HDR)], this does not function.
- 2) The signal equivalent to HDMI 4K cannot be displayed with Quad View.
- 3) When the setting is switched individually, input the individual items to [User Preset] and set the individual [User Preset] to each view.
- 4) [Flicker Free] functions as follows during Quad View:
  - When Screen A to D are all SDR: [On]/[Off] can be selected for [Flicker Free]
  - When HDR is included in Screen A to D: [On] is always selected for [Flicker Free]

## Rear Panel

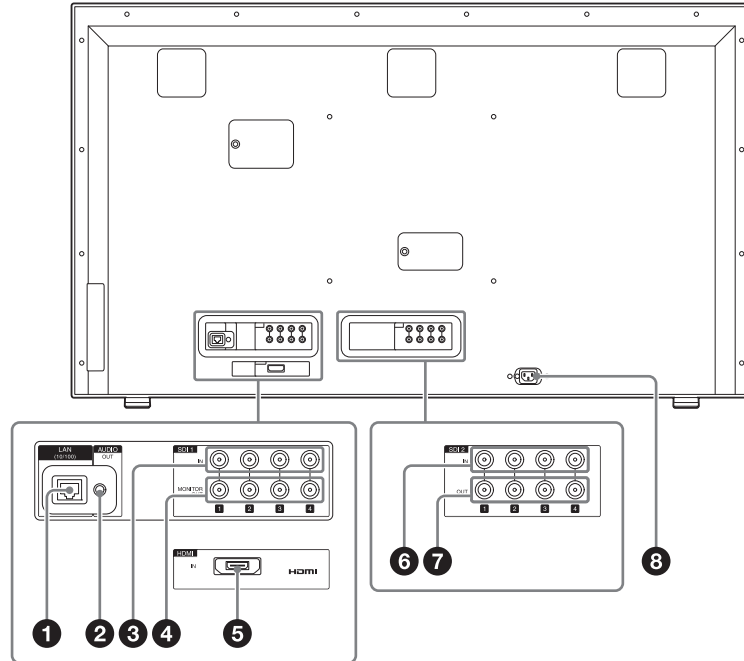

### 1 LAN (10/100) connector

Connect to the Sony BKM-16R Monitor Control Unit by using a 10BASE-T/100BASE-TX LAN cable (shielded type, optional).

#### CAUTION

- For safety, do not connect the connector for peripheral device wiring that might have excessive voltage to this port. Follow the instructions for this port.
- When you connect the LAN cable of the unit to peripheral device, use a shielded-type cable to prevent malfunction due to radiation noise.
- The connection speed may be affected by the network system. This unit does not guarantee the communication speed or quality of 10BASE-T/100BASE-TX.

#### ATTENTION

Par mesure de sécurité, ne raccordez pas le connecteur pour le câblage de périphériques pouvant avoir une tension excessive à ce port. Suivez les instructions pour ce port.

#### VORSICHT

Aus Sicherheitsgründen nicht mit einem Peripheriegerät-Anschluss verbinden, der zu starke Spannung für diese Buchse haben könnte. Folgen Sie den Anweisungen für diese Buchse.

#### ОСТОРОЖНО

- В целях обеспечения безопасности не подключайте к этому порту соединительные разъемы

электропроводки периферических устройств, которые, возможно, имеют чрезмерно высокое напряжение. Соблюдайте инструкции, предписанные для порта.

- Для избежания неисправностей, вызванных электромагнитным шумом, используйте экранированный кабель при подключении кабеля LAN аппарата к периферийному устройству.

#### АБАЙЛАҢЫЗ

- Қауіпсіздік үшін коннекторды портқа артық кернеу салмағын түсіретін қосымша құрылғының кабелін жалғаманыз. Порттың нұсқаулығын қараңыз.
- Құрылғының LAN кабелі қосымша құрылғыға жалғанған кезде радиоактивті кедергілердің алдын алу үшін қорғалған кабельдерді пайдаланыңыз.

### 2 AUDIO OUT (audio output) connector (stereo mini jack)

The audio signal of the input signal which is selected by the ASSIGN 1/2 button on the side panel is output. The output audio signal can be changed in [Audio Setting] (page 34) of the [User Configuration] menu.

### 3 SDI 1 IN (SDI 1 input) connectors (BNC)

Input connectors for serial digital signals.

For details, see “Connecting the SDI Signals” (page 39).

### 4 MONITOR OUT (SDI output) connectors (BNC)

Output connectors for serial digital signals.

Outputs the signal that is input to the SDI 1 IN connector when the SDI 1 IN connector signal is displayed.

The **1** to **4** connectors output the signal that is input to the corresponding SDI IN connector.

Outputs the signal that is input to the SDI 2 IN connector when the SDI 2 IN connector signal is displayed.

The **1** to **4** connectors output the signal that is input to the corresponding SDI IN connector.

Outputs the signal that is input to the SDI 1/2 IN connector when the signal that is input to the HDMI IN connector is displayed.

**Note**

SDI output is only activated when the power is on.

**5 HDMI IN (HDMI input) connector**

Input connector for HDMI <sup>1)</sup> signals.

HDMI (High-Definition Multimedia Interface) is an interface that supports both video and audio on a single digital connection, allowing you to enjoy high quality digital picture and sound. The HDMI specification supports HDCP (High-bandwidth Digital Content Protection), a copy protection technology that incorporates coding technology for digital video signals.

- 1) The terms HDMI and HDMI High-Definition Multimedia Interface, and the HDMI Logo are trademarks or registered trademarks of HDMI Licensing LLC in the United States and other countries.

**Note**

To input the HDMI signal equivalent to 4K, use an HDMI cable bearing the Premium High Speed logo within a length of 3 meters.

To input other signals, we recommend using a Premium High Speed HDMI cable within a length of 3 meters.

**6 SDI 2 IN (SDI 2 input) connectors (BNC)**

Input connectors for serial digital signals.

For details, see “Connecting the SDI Signals” (page 39).

**7 SDI 2 OUT (SDI 2 output) connectors (BNC)**

Output connectors for serial digital signals.

The **1** to **4** connectors output the signal that is input to the corresponding SDI 2 IN connector.

**Note**

SDI output is only activated when the power is on.

**8 AC IN socket**

Connect the supplied AC power cord.

# Attaching the Monitor Stand

- 1 Place the monitor facing down on a soft cloth.
- 2 Attach the monitor stand with the supplied screws.

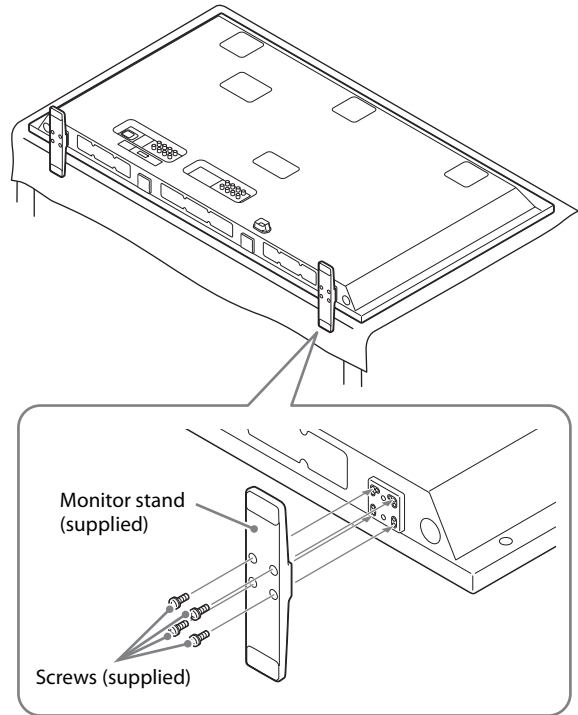

**Notes**

- Make sure to tighten the screws using the screwdriver which conforms to the supplied screws.
- When using an electric screwdriver, set the torque setting to approximately 1.2 N·m [12 kgf·cm].
- The Monitor stand has a front and back direction. Attach the monitor stand so that the protrusion of the monitor stand faces the back side of the monitor as shown in the figure.

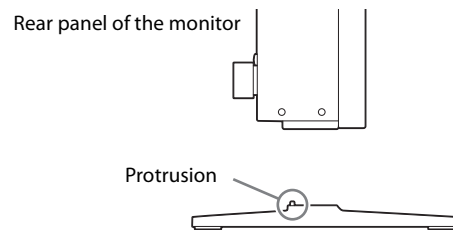

- Remove the monitor stand when storing the unit using the original packing box to prevent damage of the stand attachment part.

## Connecting the AC Power Cord

- 1 Plug the AC power cord into the AC IN socket on the rear panel. Then, attach the AC plug holder (supplied) to the AC power cord.

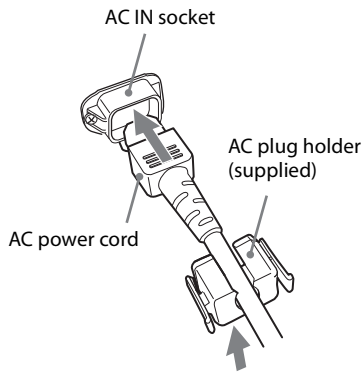

- 2 Slide the AC plug holder over the cord until it locks.

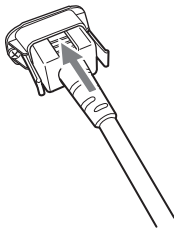

### To remove the AC power cord

Pull out the AC plug holder while pressing the lock levers.

## Connecting the HDMI cable

- 1 Remove the two screws on the both sides of the HDMI IN connector.

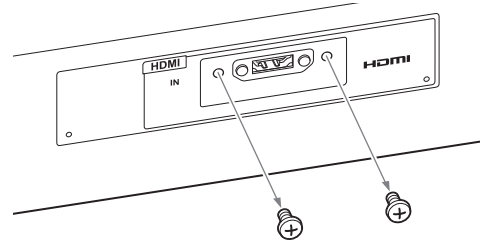

- 2 Attach the HDMI cable holder (supplied) with the removed screws.

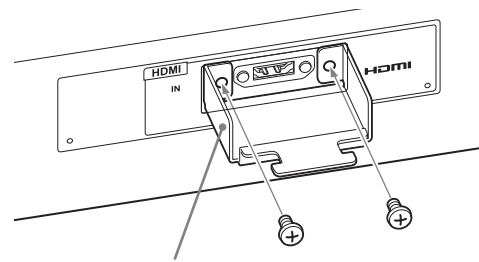

- 3 Insert the HDMI cable and fix with a commercially-available cable fixer (1 piece).

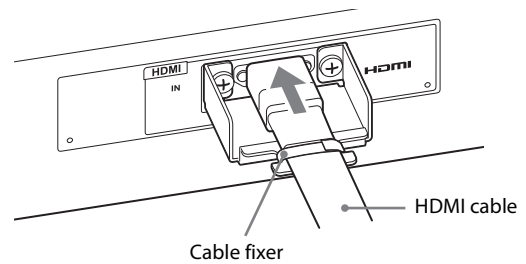



# Using the Menu

The unit is equipped with an on-screen menu for making various adjustments and settings such as picture control, input setting, set setting change, etc.

The current settings are displayed in place of the ■■■■ marks on the illustrations of the menu screen.

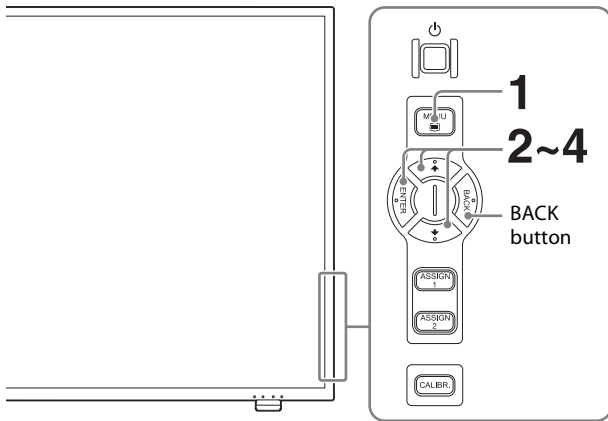

**1** Press the MENU button.

The menu appears.  
The menu presently selected is shown in yellow.

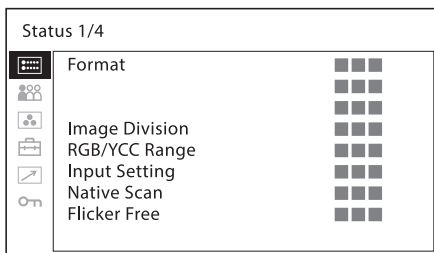

**2** Press the ▲/▼ button to select a menu, then press the ENTER button.

The menu icon presently selected is shown in yellow and setting items are displayed.

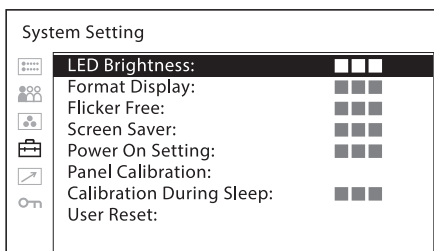

**3** Select an item.

Press the ▲/▼ button to select the item, then press the ENTER button.

The item to be changed is displayed in yellow.

If the menu consists of multiple pages, press the ▲/▼ button to go to the desired menu page.

**4** Make the setting or adjustment on an item.

### When changing the adjustment level:

To increase the number, press the ▲ button.

To decrease the number, press the ▼ button.

Press the ENTER button to confirm the number, then restore the original screen.

### When changing the setting:

Press the ▲/▼ button to change the setting, then press the ENTER button to confirm the setting.

### When returning the adjustment or setting to the previous value:

Press the BACK button before pressing the ENTER button.

### Notes

- An item displayed in black cannot be accessed. You can access the item if it is displayed in white.
- If the [Password Lock] has been turned [On], the setting values of the color temperature for [User1] and the User Preset for [User Preset1] cannot be changed. To change the values, enter the password.

*For details on the password lock function, see "[Security] menu" (page 39).*

### To return the display to the previous screen

Press the BACK button.

### To clear the menu

Press the MENU button.

The menu disappears automatically if a button is not pressed for one minute.

### About the memory of the settings

The settings are automatically stored in the monitor memory.

## Switching the Input Signal

The ASSIGN 1/2 buttons on the side panel of this unit or the numeric buttons of the optional Sony Monitor Control Unit BKM-16R can switch input signals that are compatible to each input connector of this unit (SDI1 4K, SDI1 2K, SDI2 4K, SDI2 2K, or HDMI).

The following operations are available in the factory default settings of each button.

### To switch by using the ASSIGN 1 button of this unit

- 1 Press the ASSIGN 1 button.  
[Input Select/Input Setting] menu is displayed.
- 2 Select [Input Select].
- 3 Select the input signal to the monitor from [SDI1 4K], [SDI1 2K], [SDI2 4K], [SDI2 2K], or [HDMI].

### To switch by using the numeric buttons of BKM-16R

Each input signal compatible to this unit is assigned to the 1 to 5 buttons. Switch the input signal to the monitor by pressing a button.

- 1 button: [SDI1 4K]
- 2 button: [SDI1 2K]
- 3 button: [SDI2 4K]
- 4 button: [SDI2 2K]
- 5 button: [HDMI]

#### Note

Check the settings of each button in the following menu if the factory default settings are changed.

- ASSIGN 1/2 buttons of this unit: [Assign Button Setting] (page 33)
- Numeric buttons of BKM-16R: [Function/Numeric Button Setting] (page 38)

## Protection of the Setting Values

You can protect the setting values of the color temperature for [User1] and the User Preset for [User Preset1] using [Password Lock].

When the values are protected with a password, you need to enter the password during the following operations.

- When you change the color temperature values for [User1] using [Adjust Gain/Bias] or [Copy From].
- When you change the User Preset values for [User Preset1].

*For details, see [Password Lock] (page 39).*

# Adjustment Using the Menus

## Items

The screen menu of this monitor consists of the following items.

### **[Status] (the items indicate the current settings.)**

Displays the unit setting status, etc.

For details on the displayed items, see “[Status] menu” (page 23).

### **[User Preset Setting]**

- [User Preset]
- [Color Temp.]
- [Contrast]
- [Brightness]
- [Chroma]
- [Aperture]
- [Marker Preset]
- [Copy From]

### **[Color Temp.]**

- [Color Temp.]
  - [R/G/B Gain]
  - [R/G/B Bias]
- [Manual Adjustment]
  - [Adjust Gain/Bias]
  - [Signal]
- [Copy From]

### **[User Configuration]**

- [System Setting]
  - [LED Brightness]
  - [Format Display]
  - [Flicker Free]
  - [Screen Saver]
  - [Power On Setting]
  - [Panel Calibration]
  - [Calibration During Sleep]
  - [User Reset]
- [Input Setting]
  - [SDI1 4K/UHD Input Setting]
  - [SDI1 2K/HD Input Setting]
  - [SDI2 4K/UHD Input Setting]
  - [SDI2 2K/HD Input Setting]
  - [HDMI Input Setting]
  - [Assign Button Setting]

- [Audio Setting]
  - [SDI Audio Setting]
- [Internal Signal Setting]
  - [Internal Signal]
  - [Pattern]
- [Gamut Marker Setting]
  - [Gamut Marker]
  - [Target]
  - [Type]
- [Area and Aspect Marker Setting]
  - [Marker Preset]
  - [Aspect Marker Setting]
  - [Area Marker1 Setting]
  - [Area Marker2 Setting]
  - [Center Marker Setting]
- [Quad View Setting]
  - [Quad View Display]
  - [Input Port]
  - [Screen Setting]

### **[Serial Remote]**

- [Monitor]
  - [Network Setting]
  - [Connection]
- [Controller]
  - [Network Setting]
  - [Function/Numeric Button Setting]

### **[Security]**

- [Password Lock]
  - [Color Temp./User Pre.]
  - [Change Password]

## Adjusting and Changing the Settings

### **[Status] menu**

The status menu displays the current status of the unit. The following items are displayed:

#### Page 1

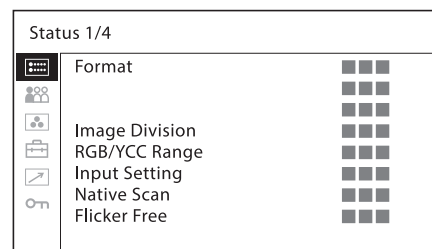

- [Format]
- [Image Division]
- [RGB/YCC Range]
- [Input Setting]

- [Native Scan]
- [Flicker Free]

### Page 2

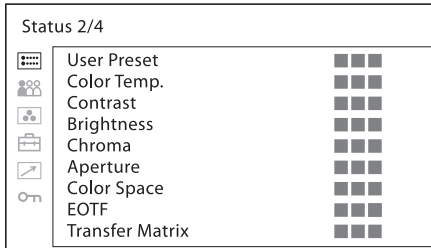

- [User Preset]
- [Color Temp.]
- [Contrast]
- [Brightness]
- [Chroma]
- [Aperture]
- [Color Space]
- [EOTF]
- [Transfer Matrix]

### Page 3 (for the SDI signal input)

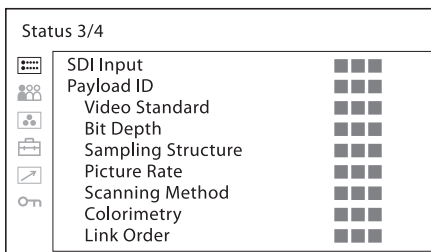

- [SDI Input]
- [Payload ID]
- [Video Standard]
- [Bit Depth]
- [Sampling Structure]
- [Picture Rate]
- [Scanning Method]
- [Colorimetry]
- [Link Order]

### Page 3 (for the HDMI signal input)

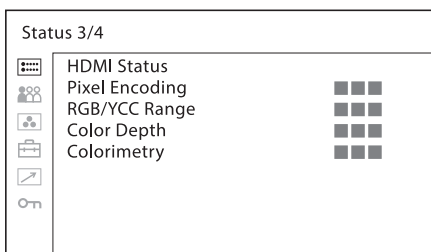

- [HDMI Status]
- [Pixel Encoding]
- [RGB/YCC Range]
- [Color Depth]

- [Colorimetry]

### Page 4

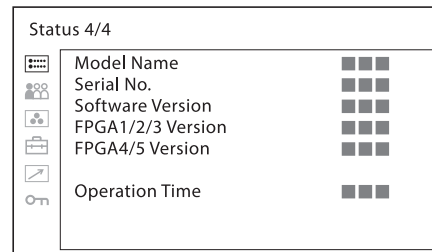

- [Model Name]
- [Serial No.]
- [Software Version]
- [FPGA1/2/3 Version]
- [FPGA4/5 Version]
- [Operation Time]

#### Note

Title displays in the [Status] menu differ during Quad View.

### [User Preset Setting] menu

You can select the User Preset to be used, or set and adjust various items. The preset values can be copied from other preset data.

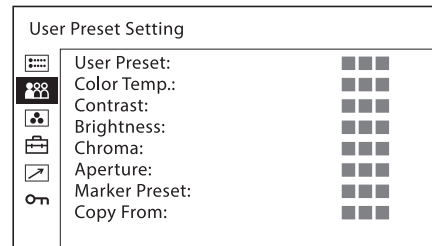

Submenu	Setting
---------	---------

[User Preset]	Select the User Preset data to be applied. <ul style="list-style-type: none"> <li>• [User Preset1]</li> <li>• [User Preset2]</li> <li>• [User Preset3]</li> <li>• [User Preset4]</li> <li>• [User Preset5]</li> <li>• [User Preset XYZ]</li> </ul>
---------------	--

#### Note

When the XYZ format signal is input, set to [User Preset XYZ].

Submenu	Setting
[Color Temp.]	Select the color temperature to be used in the selected User Preset. <ul style="list-style-type: none"> <li>• [D65]</li> <li>• [D93]</li> <li>• [D61]</li> <li>• [D55]</li> <li>• [DCI]</li> <li>• [User1]</li> <li>• [User2]</li> <li>• [User3]</li> <li>• [User4]</li> <li>• [User5]</li> <li>• [DCI XYZ]</li> </ul>

**Notes**

- If you measure the color temperatures of different display types, such as CRT, LCD, or OLED, by using a common (or general) color analyzer that is based on CIE 1931, and adjust the xy chromaticity to the same value, the appearance may be different because of optical spectrum differences. To compensate for this difference, the [D65], [D93], [D61], and [D55] settings of the monitor are adjusted by an offset <sup>1)</sup>.
- When the XYZ format signal is input, set to [DCI XYZ].

[Contrast]	Set the contrast of the selected User Preset.
[Brightness]	Set the brightness of the selected User Preset.
[Chroma]	Set the chroma level of the selected User Preset.

**Note**

When [S-Log3(HDR)], [S-Log2(HDR)], [SMPTE ST 2084(HDR)], [HLG SG 1.2(HDR)] or [HLG SG Variable(HDR)] is selected for [EOTF] in the [Input Setting] menu, this does not function. For details on the EOTF setting, see page 29.

[Aperture]	Set the aperture of the selected User Preset.
[Marker Preset]	Select the marker preset to be used in the selected User Preset. <ul style="list-style-type: none"> <li>• [Marker Preset1]</li> <li>• [Marker Preset2]</li> <li>• [Marker Preset3]</li> <li>• [Marker Preset4]</li> <li>• [Marker Preset5]</li> </ul>

Submenu	Setting
[Copy From]	Copies the other User Preset data to the selected User Preset. The appropriate settings are saved in [Default(D65)] for D65, [Default(D93)] for D93, and [Default(XYZ)] for XYZ format signal. <ul style="list-style-type: none"> <li>• [User Preset1]</li> <li>• [User Preset2]</li> <li>• [User Preset3]</li> <li>• [User Preset4]</li> <li>• [User Preset5]</li> <li>• [Default(D65)]</li> <li>• [Default(D93)]</li> <li>• [User Preset XYZ]</li> <li>• [Default(XYZ)]</li> </ul>

1) The offset value applied (x -0.008, y -0.012) is based on the Judd's function to the CIE 1931 (x, y) value.

 **[Color Temp.] menu**

You can select and adjust the color temperature. You need to use the measurement instrument to adjust the white balance.

Recommended: Konica Minolta Color Analyzer CA-210/310

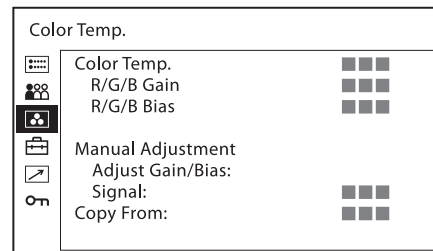

Submenu	Setting
[Manual Adjustment]	If you set the [Color Temp.] to the [User1] to [User5] setting, you can adjust the color temperature. The set values are memorized. <ul style="list-style-type: none"> <li>• <b>[Adjust Gain/Bias]:</b> <ul style="list-style-type: none"> <li>• <b>[R/G/B Gain]:</b> Adjusts the color balance (gain) of R (red)/G (green)/B (blue).</li> <li>• <b>[R/G/B Bias]:</b> Adjusts the color balance (bias) of R (red)/G (green)/B (blue).</li> </ul> </li> <li>• <b>[Signal]:</b> <ul style="list-style-type: none"> <li>• <b>[Internal]:</b> Select to adjust the white balance by using the internal signal. When the XYZ format signal is input, the internal signal is displayed as D65 48cd/m<sup>2</sup>.</li> <li>• <b>[External]:</b> Select to adjust the white balance by using the signals input from an external device.</li> </ul> </li> </ul>

Submenu	Setting
[Copy From]	Select from the following items to copy the white balance data of the selected color temperature. <ul style="list-style-type: none"> <li>• [D65]</li> <li>• [D93]</li> <li>• [D61]</li> <li>• [D55]</li> <li>• [DCI]</li> <li>• [User1]</li> <li>• [User2]</li> <li>• [User3]</li> <li>• [User4]</li> <li>• [User5]</li> <li>• [DCI XYZ]</li> </ul>

#### Notes

- If [Password Lock] has been turned [On], the [User1] value is protected by a password. To change the values, enter the password.
- The color temperature data is used commonly regardless of the signal format or the EOTF setting. When the color temperature is adjusted under certain conditions, the adjusted result is reflected in all displays on which the same color temperature data is set.

## [User Configuration] menu

Executes [System Setting], [Input Setting], [Assign Button Setting], [Audio Setting], [Internal Signal Setting], [Gamut Marker Setting], [Area and Aspect Marker Setting], and [Quad View Setting].

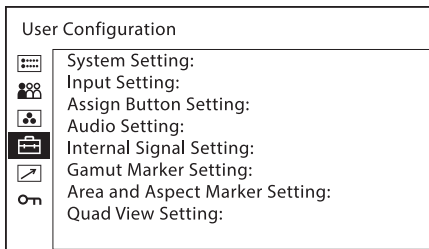

## [System Setting]

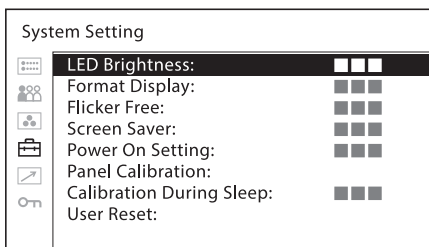

Submenu	Setting
[LED Brightness]	Selects the brightness of the indicator's LED of the buttons, power switch, etc. <ul style="list-style-type: none"> <li>• <b>[High]</b>: The level of the LED brightness becomes high.</li> <li>• <b>[Low]</b>: The level of the LED brightness becomes low.</li> </ul>
[Format Display]	Selects the display mode of the signal format. <ul style="list-style-type: none"> <li>• <b>[Auto]</b>: The format is displayed for about five seconds when the input of the signal starts.</li> <li>• <b>[Off]</b>: The display is hidden.</li> </ul>
[Flicker Free]	Set this to [On] to enable view images without flicker. An OLED panel can provide superior video responsiveness and scan driving, reproducing images with little contour or afterimage. However, scan driving can cause flicker when input signals have a low vertical frequency (24P/PsF, 50i, etc.). Set [Flicker Free] to [On] to greatly reduce this phenomenon. With this mode set to on, quick-moving images may exhibit contours or an afterimage.

#### Notes

- In the HDR display, [Flicker Free] cannot be selected. Always set to [On].
- When [Flicker Free] is set to [Off], the whole screen becomes dark. The display of the menu, etc. also becomes dark. To check the brightness, set [Flicker Free] to [On].

*For details on the HDR (High Dynamic Range) display, see page 29.*



Submenu	Setting
[Screen Saver]	<p>Sets the screen saver function [On] or [Off].</p> <ul style="list-style-type: none"> <li>• <b>[On]:</b> If a still image is displayed for more than 10 minutes, the brightness of the screen is automatically decreased to reduce burn-in. The screen returns to normal brightness when you input a video signal to the unit or operate the buttons on the side panel of the unit. While the screen saver is active, the STATUS indicator flashes every two seconds. Before the screen saver starts up, the STATUS indicator flashes every second to notify users that the screen saver will start up.</li> <li>• <b>[Off]:</b> The screen saver function is deactivated.</li> </ul> <p><b>Note</b></p> <p>In the HDR display, this setting is forcibly set to [On].</p> <p><i>For details on the HDR (High Dynamic Range) display, see page 29.</i></p>

[Power On Setting]	<p>Sets this unit's setting status after the unit is turned on. Select from [Last Memory], [User Preset1], [User Preset2], [User Preset3], [User Preset4], [User Preset5] or [User Preset XYZ].</p>
--------------------	---

[Panel Calibration]	<p>Select to adjust the uniformity of the screen.</p> <p>When selected, the confirmation screen is displayed. Select [Confirm] to perform Panel Calibration and select [Cancel] to cancel Panel Calibration. When the CALIBR. button on the monitor or the 0 button on the Sony monitor control unit is pressed, the confirmation screen is displayed. When Panel Calibration is completed successfully, the monitor changes to the sleep mode.</p>
---------------------	---

**Notes**

- Perform Panel Calibration in the range of the recommended environmental temperature (20 °C to 30 °C (68 °F to 86 °F)).
- The monitor screen remains black for 10 to 30 minutes once performing is started. A faint horizontal line may be displayed depending on the status.
- The fan activates during Panel Calibration.

Submenu	Setting
	<ul style="list-style-type: none"> <li>• If the power turns off/on during Panel Calibration, the process is not completed successfully. Therefore, you need to perform Panel Calibration the next time you turn on the power. When Panel Calibration is not completed successfully, the [Recommend Re-calibration] message is displayed. Perform Panel Calibration again. If the message is displayed after performing Panel Calibration a few times, it may be due to a failure. Contact an authorized Sony dealer.</li> <li>• It is recommended to perform Panel Calibration once a week since it is effective to improve the uniformity of the screen.</li> <li>• When the CALIBR. indicator lights in yellow, make sure to perform Panel Calibration. At this time, the [Recommend Calibration] message is displayed. Use this unit without performing Panel Calibration. It may not improve the uniformity of the screen even if Panel Calibration is performed.</li> </ul>

[Calibration During Sleep]	<p>Set this to perform Panel Calibration automatically while in the sleep mode. "Sleep mode" refers to the status when the MONITOR   / (⏻) switch of the Sony monitor control unit is pressed. Approximately 5 minutes after changing to the sleep mode, Panel Calibration is performed automatically. At this time, the CALIBR. indicator blinks in yellow. When Panel Calibration is completed, it goes back to sleep mode and the CALIBR. indicator turns off.</p>
----------------------------	---

[User Reset]	<p>Returns to the factory default setting except for the following:</p> <ul style="list-style-type: none"> <li>• Color temperature for [User1]</li> <li>• Color temperature for [User2]</li> <li>• Color temperature for [User3]</li> <li>• Color temperature for [User4]</li> <li>• Color temperature for [User5]</li> <li>• User Preset for [User Preset1]</li> <li>• Network setting of the monitor</li> <li>• Password setting</li> </ul> <ul style="list-style-type: none"> <li>• <b>[Cancel]:</b> Cancels reset.</li> <li>• <b>[Confirm]:</b> Resets the unit.</li> </ul>
--------------	---

## [Input Setting]

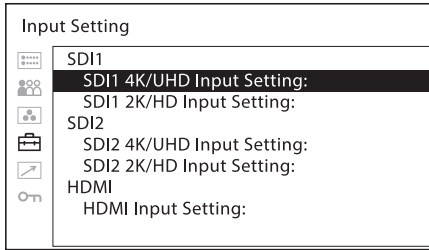

## [SDI1 4K/UHD Input Setting] / [SDI2 4K/UHD Input Setting]

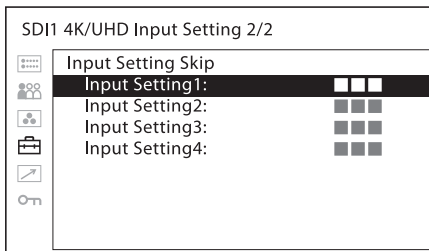
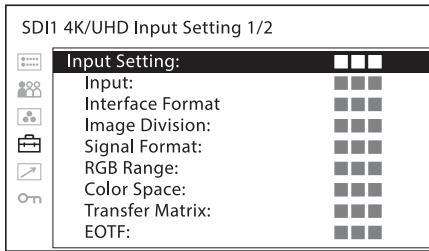

Submenu	Setting
[Input Setting]	Sets the input setting of the SDI 4K signal. <ul style="list-style-type: none"> <li>[Input Setting1]</li> <li>[Input Setting2]</li> <li>[Input Setting3]</li> <li>[Input Setting4]</li> </ul>
[Input]	Set the input connector of the SDI 4K signal. <ul style="list-style-type: none"> <li>[Input1,2,3&amp;4]: Select to use SDI IN <b>1</b>, SDI IN <b>2</b>, SDI IN <b>3</b>, and SDI IN <b>4</b> with Quad Link.</li> <li>[Input1&amp;2]: Select to use SDI IN <b>1</b> and SDI IN <b>2</b> with Dual Link.</li> <li>[Input3&amp;4]: Select to use SDI IN <b>3</b> and SDI IN <b>4</b> with Dual Link.</li> </ul>
[Interface Format]	Displays the interface format of the 4K input. <ul style="list-style-type: none"> <li>[Quad-Link 3G/HD-SDI]</li> <li>[Dual-Link 3G-SDI]</li> </ul>
[Image Division]	Set the image division of the 4K input. <ul style="list-style-type: none"> <li>[Auto]: Select for the Auto setting.</li> <li>[2SI]: Select to receive images of the 2 sample Interleave system.</li> <li>[Square]: Select to receive images of the Square system.</li> </ul>

Submenu	Setting
[Signal Format]	Select from the following when [Interface Format] is [Quad-Link 3G/HD-SDI]. <ul style="list-style-type: none"> <li>[Auto]</li> <li>[422 YCbCr 10bit]</li> <li>[444 RGB 10bit]</li> <li>[444 YCbCr 10bit]</li> <li>[444 RGB 12bit]</li> <li>[444 YCbCr 12bit]</li> <li>[444 XYZ 12bit]</li> </ul> <p>[422 YCbCr 10bit] is set when [Interface Format] is [Dual-Link 3G-SDI].</p>
[RGB Range]	Select from the following when [Signal Format] is set to RGB. <ul style="list-style-type: none"> <li>[Full]: 0 to 1023 (10bit) / 0 to 4095 (12bit)</li> <li>[Limited]: 64 to 940 (10bit) / 256 to 3760 (12bit)</li> <li>[SDI Full Range]<sup>1)</sup>: 4 to 1019 (10bit) / 16 to 4079 (12bit)</li> </ul> <p>1) This manual regards the Full Range signals that are scaled to the quantized value except the inhibit code on the SDI standard as the SDI Full Range.</p>
[Color Space]	Select the color space from the following: <ul style="list-style-type: none"> <li>[ITU-R BT.709]</li> <li>[EBU]</li> <li>[SMPTE-C]</li> <li>[Native]</li> <li>[S-Gamut/S-Gamut3]</li> <li>[S-Gamut3.Cine]</li> <li>[DCI-P3]</li> <li>[ITU-R BT.2020]</li> </ul>
[Transfer Matrix]	Select the transfer matrix from the following: <ul style="list-style-type: none"> <li>[ITU-R BT.709]</li> <li>[ITU-R BT.2020]</li> </ul> <p>Set the following depending on the [Color Space] setting.</p> <p>When [ITU-R BT.2020] is selected: Select [ITU-R BT.2020].</p> <p>When [ITU-R BT.709] is selected: Select [ITU-R BT.709].</p> <p>When another item is selected: Select the transfer matrix setting of the device which outputs the signal.</p>

### Note

When [Signal Format] is set to [Auto] or [444 XYZ 12bit] and the XYZ signal is input, the optimum setting for the XYZ signal is fixed.

### Note

When [Signal Format] is set to [Auto] or [444 XYZ 12bit] and the XYZ signal is input, the optimum setting for the XYZ signal is fixed.

Submenu	Setting
[EOTF]	Select the gamma from the following: <ul style="list-style-type: none"> <li>• [2.2]</li> <li>• [2.4]</li> <li>• [2.6]</li> <li>• [CRT]</li> <li>• [2.4(HDR)]</li> <li>• [S-Log3(HDR)]</li> <li>• [S-Log2(HDR)]</li> <li>• [SMPTE ST 2084(HDR)]</li> <li>• [HLG SG 1.2(HDR)]<sup>1)</sup></li> <li>• [HLG SG Variable(HDR)]<sup>1)</sup></li> </ul> 1) The unit corresponds to the HLG (Hybrid Log-Gamma). Refer to “HLG specification” (page 29).
	When [HLG SG Variable(HDR)] is selected <ul style="list-style-type: none"> <li>• <b>[HLG System Gamma]</b>: Sets the system gamma of the HLG. Set from 1.000 to 1.500.</li> </ul>

**Note**

The HDR display is a method to faithfully display the brightness of signals defined of 100% or more level without compressing the brightness parts.

- You can check the bright portions exceeding the displayable brightness of the unit by decreasing the contrast.
- In the HDR display, the screen saver is forcibly set. [Off] cannot be selected.
- In the HDR display, [Flicker Free] is forcibly set. [Off] cannot be selected.
- Using the unit with the high brightness display for extended periods may cause eyestrain or reduction of eyesight. Be sure to take an occasional break when using.
- Follow RECOMMENDATION ITU-R BT.1702 “Guidance for the reduction of photosensitive epileptic seizures caused by television” or other guidelines to use.
- In the HDR display, the display surface may emit heat when high brightness images are output. Do not touch the surface.
- Do not display static images that contains high brightness display, time codes, markers, or logos for extended periods to reduce the risk of burn-in. Consider to apply a displaying method with a low level signals of 100% or less.

Submenu	Setting
	<ul style="list-style-type: none"> <li>• If a high level signal is continuously displayed on the same area in the HDR display, the protection function activates wherein the brightness of the bright part in the display decreases to control the rise of the surface temperature of the OLED panel. When the level of the bright part decreases or the change of its position continues, the protection function is deactivated. However, it may take a while to deactivate.</li> <li>• When [Signal Format] is set to [Auto] or [444 XYZ 12bit] and the XYZ signal is input, the optimum setting for the XYZ signal is fixed.</li> </ul>
[Input Setting Skip]	Sets the skip setting when changing the input setting. Select [Skip]/[Not Skip] for each input setting of [Input Setting1] to [Input Setting4]. <ul style="list-style-type: none"> <li>• <b>[Skip]</b>: Skips.</li> <li>• <b>[Not Skip]</b>: Does not skip.</li> </ul>

**HLG specification**

The EOTF's selection on the unit	HLG EOTF		
	EOTF	×	OOTF
[HLG SG 1.2(HDR)]	[HLG OETF] <sup>-1</sup>	×	System gamma = 1.2
[HLG SG Variable(HDR)]		×	System gamma = Variable <sup>2)</sup>

1) HLG OETF: provided by ARIB STD-B67  
 2) Refer to BBC White Paper WHP309

**[SDI1 2K/HD Input Setting] / [SDI2 2K/HD Input Setting]**

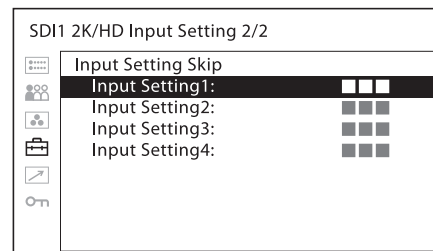
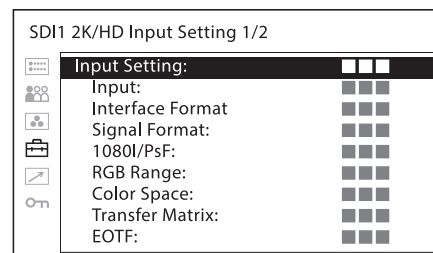

Submenu	Setting
[Input Setting]	Sets the input setting of the SDI 2K signal. <ul style="list-style-type: none"> <li>• [Input Setting1]</li> <li>• [Input Setting2]</li> <li>• [Input Setting3]</li> <li>• [Input Setting4]</li> </ul>
[Input]	Set the input connector of the SDI 2K signal. <ul style="list-style-type: none"> <li>• <b>[Input1]</b>: Select to use SDI IN <b>[1]</b> with Single Link.</li> <li>• <b>[Input2]</b>: Select to use SDI IN <b>[2]</b> with Single Link.</li> <li>• <b>[Input3]</b>: Select to use SDI IN <b>[3]</b> with Single Link.</li> <li>• <b>[Input4]</b>: Select to use SDI IN <b>[4]</b> with Single Link.</li> <li>• <b>[Input1&amp;2]</b>: Select to use SDI IN <b>[1]</b> and SDI IN <b>[2]</b> with Dual Link.</li> <li>• <b>[Input3&amp;4]</b>: Select to use SDI IN <b>[3]</b> and SDI IN <b>[4]</b> with Dual Link.</li> </ul>
[Interface Format]	Displays the interface format of the 2K input. <ul style="list-style-type: none"> <li>• <b>[Single-Link 3G/HD-SDI]</b>: For Single Link.</li> <li>• <b>[Dual-Link 3G/HD-SDI]</b>: For Dual Link of 3G/HD-SDI.</li> </ul>
[Signal Format]	Select from the following when [Interface Format] is [Single-Link 3G/HD-SDI]. <ul style="list-style-type: none"> <li>• [Auto]</li> <li>• [422 YCbCr 10bit]</li> <li>• [444 RGB 10bit]</li> <li>• [444 YCbCr 10bit]</li> <li>• [444 RGB 12bit]</li> <li>• [444 YCbCr 12bit]</li> <li>• [444 XYZ 12bit]</li> </ul> <p>Select from the following when [Interface Format] is [Dual-Link 3G/HD-SDI].</p> <ul style="list-style-type: none"> <li>• [Auto]</li> <li>• [444 RGB 10bit]</li> <li>• [444 YCbCr 10bit]</li> <li>• [444 RGB 12bit]</li> <li>• [444 YCbCr 12bit]</li> <li>• [444 XYZ 12bit]</li> <li>• [422 YCbCr 10bit]</li> </ul>
[1080I/PsF]	Set how to display when 50I, 59.94I, 60I, 25PsF, 29.97PsF, or 30PsF signals are input in the SDI 2K input. 23.98 Hz and 24 Hz signals are processed as the PsF signal. <ul style="list-style-type: none"> <li>• <b>[Auto]</b>: When Payload ID is added to SDI signals, they are processed based on the ID data. They are processed as the interlace signals without the Payload ID.</li> <li>• <b>[PsF]</b>: Processes as the PsF signal.</li> <li>• <b>[Interlace]</b>: Processes as the interlace signal.</li> </ul>

Submenu	Setting
[RGB Range]	Select from the following when [Signal Format] is set to RGB. <ul style="list-style-type: none"> <li>• <b>[Full]</b>: 0 to 1023 (10bit) / 0 to 4095 (12bit)</li> <li>• <b>[Limited]</b>: 64 to 940 (10bit) / 256 to 3760 (12bit)</li> <li>• <b>[SDI Full Range]</b> <sup>1)</sup>: 4 to 1019 (10bit) / 16 to 4079 (12bit)</li> </ul> <p>1) This manual regards the Full Range signals that are scaled to the quantized value except the inhibit code on the SDI standard as the SDI Full Range.</p>
[Color Space]	Select the color space from the following: <ul style="list-style-type: none"> <li>• [ITU-R BT.709]</li> <li>• [EBU]</li> <li>• [SMPTE-C]</li> <li>• [Native]</li> <li>• [S-Gamut/S-Gamut3]</li> <li>• [S-Gamut3.Cine]</li> <li>• [DCI-P3]</li> <li>• [ITU-R BT.2020]</li> </ul>
<b>Note</b>	
	When [Signal Format] is set to [Auto] or [444 XYZ 12bit] and the XYZ signal is input, the optimum setting for the XYZ signal is fixed.
[Transfer Matrix]	Select the transfer matrix from the following: <ul style="list-style-type: none"> <li>• [ITU-R BT.709]</li> <li>• [ITU-R BT.2020]</li> </ul> <p>Set the following depending on the [Color Space] setting.</p> <p>When [ITU-R BT.2020] is selected: Select [ITU-R BT.2020].</p> <p>When [ITU-R BT.709] is selected: Select [ITU-R BT.709].</p> <p>When another item is selected: Select the transfer matrix setting of the device which outputs the signal.</p>
<b>Note</b>	
	When [Signal Format] is set to [Auto] or [444 XYZ 12bit] and the XYZ signal is input, the optimum setting for the XYZ signal is fixed.

Submenu	Setting
[EOTF]	<p>Select the gamma from the following:</p> <ul style="list-style-type: none"> <li>• [2.2]</li> <li>• [2.4]</li> <li>• [2.6]</li> <li>• [CRT]</li> <li>• [2.4(HDR)]</li> <li>• [S-Log3(HDR)]</li> <li>• [S-Log2(HDR)]</li> <li>• [SMPTE ST 2084(HDR)]</li> <li>• [HLG SG 1.2(HDR)]<sup>1)</sup></li> <li>• [HLG SG Variable(HDR)]<sup>1)</sup></li> </ul> <p>1) The unit corresponds to the HLG (Hybrid Log-Gamma). Refer to “HLG specification” (page 29).</p> <p>When [HLG SG Variable(HDR)] is selected</p> <ul style="list-style-type: none"> <li>• <b>[HLG System Gamma]</b>: Sets the system gamma of the HLG. Set from 1.000 to 1.500.</li> </ul>

**Note**

The HDR display is a method to faithfully display the brightness of signals defined of 100% or more level without compressing the brightness parts.

- You can check the bright portions exceeding the displayable brightness of the unit by decreasing the contrast.
- In the HDR display, the screen saver is forcibly set. [Off] cannot be selected.
- In the HDR display, [Flicker Free] is forcibly set. [Off] cannot be selected.
- Using the unit with the high brightness display for extended periods may cause eyestrain or reduction of eyesight. Be sure to take an occasional break when using.
- Follow RECOMMENDATION ITU-R BT.1702 “Guidance for the reduction of photosensitive epileptic seizures caused by television” or other guidelines to use.
- In the HDR display, the display surface may emit heat when high brightness images are output. Do not touch the surface.
- Do not display static images that contains high brightness display, time codes, markers, or logos for extended periods to reduce the risk of burn-in. Consider to apply a displaying method with a low level signals of 100% or less.

Submenu	Setting
	<ul style="list-style-type: none"> <li>• If a high level signal is continuously displayed on the same area in the HDR display, the protection function activates wherein the brightness of the bright part in the display decreases to control the rise of the surface temperature of the OLED panel. When the level of the bright part decreases or the change of its position continues, the protection function is deactivated. However, it may take a while to deactivate.</li> <li>• When [Signal Format] is set to [Auto] or [444 XYZ 12bit] and the XYZ signal is input, the optimum setting for the XYZ signal is fixed.</li> </ul>
[Input Setting Skip]	<p>Sets the skip setting when changing the input setting. Select [Skip]/[Not Skip] for each input setting of [Input Setting1] to [Input Setting4].</p> <ul style="list-style-type: none"> <li>• <b>[Skip]</b>: Skips.</li> <li>• <b>[Not Skip]</b>: Does not skip.</li> </ul>

**[HDMI Input Setting] (HDMI input only)**

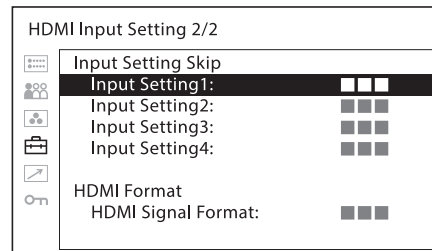
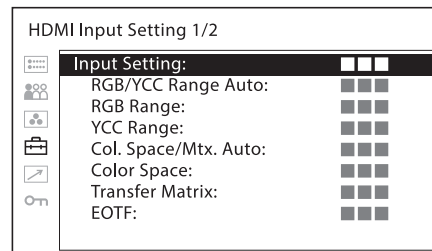

Submenu	Setting
[Input Setting]	<p>Sets the input setting of the HDMI signal.</p> <ul style="list-style-type: none"> <li>• [Input Setting1]</li> <li>• [Input Setting2]</li> <li>• [Input Setting3]</li> <li>• [Input Setting4]</li> </ul>
[RGB/YCC Range Auto]	<p>Select how to set the RGB/YCC Range.</p> <ul style="list-style-type: none"> <li>• <b>[On]</b>: Use RGB/YCC Range according to the input signal information.</li> <li>• <b>[Off]</b>: Use RGB/YCC Range that was set in the menu.</li> </ul>

Submenu	Setting
[RGB Range]	When [RGB/YCC Range Auto] is set to [Off] and the signal is RGB, select from the following: <ul style="list-style-type: none"> <li>• <b>[Full]</b>: 0 to 1023 (10bit) / 0 to 4095 (12bit)</li> <li>• <b>[Limited]</b>: 64 to 940 (10bit) / 256 to 3760 (12bit)</li> </ul>
[YCC Range]	When [RGB/YCC Range Auto] is set to [Off] and the signal is YCbCr, select from the following: <ul style="list-style-type: none"> <li>• <b>[Full]</b>: 0 to 1023 (10bit) / 0 to 4095 (12bit)</li> <li>• <b>[Limited]</b>: 64 to 940 (10bit) / 256 to 3760 (12bit)</li> </ul>
[Col. Space/Mtx. Auto]	Select how to set the color space and transfer matrix. <ul style="list-style-type: none"> <li>• <b>[On]</b>: Use the color space and transfer matrix according to the input signal information.</li> <li>• <b>[Off]</b>: Use the color space and transfer matrix that was set in the menu.</li> </ul>
[Color Space]	Select the color space from the following: <ul style="list-style-type: none"> <li>• [ITU-R BT.709]</li> <li>• [EBU]</li> <li>• [SMPTE-C]</li> <li>• [Native]</li> <li>• [S-Gamut/S-Gamut3]</li> <li>• [S-Gamut3.Cine]</li> <li>• [DCI-P3]</li> <li>• [ITU-R BT.2020]</li> </ul>

#### Note

This setting can be set only when [Col. Space/Mtx. Auto] is set to [Off].

[Transfer Matrix]	Select the transfer matrix from the following: <ul style="list-style-type: none"> <li>• [ITU-R BT.709]</li> <li>• [ITU-R BT.2020]</li> </ul> Set the following depending on the [Color Space] setting. When [ITU-R BT.2020] is selected: Select [ITU-R BT.2020]. When [ITU-R BT.709] is selected: Select [ITU-R BT.709]. When another item is selected: Select the transfer matrix setting of the device which outputs the signal.
-------------------	---

#### Note

This setting can be set only when [Col. Space/Mtx. Auto] is set to [Off].

Submenu	Setting
[EOTF]	Select the gamma from the following: <ul style="list-style-type: none"> <li>• [2.2]</li> <li>• [2.4]</li> <li>• [2.6]</li> <li>• [CRT]</li> <li>• [2.4(HDR)]</li> <li>• [S-Log3(HDR)]</li> <li>• [S-Log2(HDR)]</li> <li>• [SMPTE ST 2084(HDR)]</li> <li>• [HLG SG 1.2(HDR)] <sup>1)</sup></li> <li>• [HLG SG Variable(HDR)] <sup>1)</sup></li> </ul> <p>1) The unit corresponds to the HLG (Hybrid Log-Gamma). Refer to “HLG specification” (page 29).</p> <p>When [HLG SG Variable(HDR)] is selected</p> <ul style="list-style-type: none"> <li>• <b>[HLG System Gamma]</b>: Sets the system gamma of the HLG. Set from 1.000 to 1.500.</li> </ul>

#### Note

The HDR display is a method to faithfully display the brightness of signals defined of 100% or more level without compressing the brightness parts.

- You can check the bright portions exceeding the displayable brightness of the unit by decreasing the contrast.
- In the HDR display, the screen saver is forcibly set. [Off] cannot be selected.
- In the HDR display, [Flicker Free] is forcibly set. [Off] cannot be selected.
- Using the unit with the high brightness display for extended periods may cause eyestrain or reduction of eyesight. Be sure to take an occasional break when using.
- Follow RECOMMENDATION ITU-R BT.1702 “Guidance for the reduction of photosensitive epileptic seizures caused by television” or other guidelines to use.
- In the HDR display, the display surface may emit heat when high brightness images are output. Do not touch the surface.
- Do not display static images that contains high brightness display, time codes, markers, or logos for extended periods to reduce the risk of burn-in. Consider to apply a displaying method with a low level signals of 100% or less.

Submenu	Setting
	<ul style="list-style-type: none"> <li>If a high level signal is continuously displayed on the same area in the HDR display, the protection function activates wherein the brightness of the bright part in the display decreases to control the rise of the surface temperature of the OLED panel. When the level of the bright part decreases or the change of its position continues, the protection function is deactivated. However, it may take a while to deactivate.</li> <li>When [Signal Format] is set to [Auto] or [444 XYZ 12bit] and the XYZ signal is input, the optimum setting for the XYZ signal is fixed.</li> </ul>
[Input Setting Skip]	<p>Sets the skip setting when changing the input setting. Select [Skip]/[Not Skip] for each input setting of [Input Setting1] to [Input Setting4].</p> <ul style="list-style-type: none"> <li>[Skip]: Skips.</li> <li>[Not Skip]: Does not skip.</li> </ul>
[HDMI Format]	
[HDMI Signal Format]	<p>Change the setting to receive images in a high-resolution HDMI signal <sup>1)</sup> or a HDR-compatible HDMI signal.</p> <p>1) Signals in resolutions of 3840 × 2160 or 4096 × 2160 are listed below:</p> <p>4:4:4 RGB/YCbCr-50P/60P-8bit signals</p> <p>4:2:2 YCbCr-50P/60P-12bit signals</p> <p>4:4:4 RGB/YCbCr-24P/25P/30P-10/12bit signals</p> <ul style="list-style-type: none"> <li>[Standard Format]: Select to use for a standard HDMI format signal.</li> <li>[Enhanced Format]: Select to use for a high-resolution HDMI format signal or HDR-compatible HDMI format signal.</li> </ul>
	<p><b>Notes</b></p> <ul style="list-style-type: none"> <li>Images and sounds may not be output correctly with [Enhanced Format]. In that case, select [Standard Format].</li> <li>To display the corresponding signal with [Enhanced Format], use a Premium High-Speed HDMI cable within a length of 3 meters.</li> </ul>

## [Assign Button Setting]

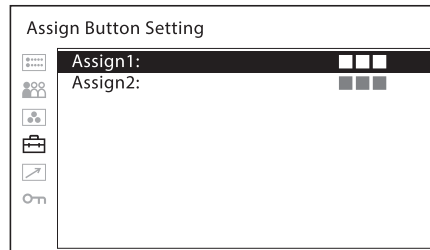

Submenu	Setting
[Assign1]	<p>Assigns functions to the ASSIGN 1 and ASSIGN 2 buttons of the side panel and turns the function on or off.</p> <p>The [Assign Button Setting] menu can also be displayed by pressing and holding the ASSIGN 1/2 button, and the setting can be changed. Note that you cannot move to another menu.</p>
[Assign2]	

## About functions assigned to the ASSIGN 1/2 buttons

### [Mono]

Press the button to display a monochrome picture. When the button is pressed again, the monitor switches automatically to color mode.

### [Blue Only]

Press the button to eliminate the red and green signals. Only the blue signal is displayed as an apparent monochrome picture on the screen. This facilitates observation of signal noise.

### [Native Scan]

Press the button to switch between the image with the scaling display ([Off]) and the image displayed directly from pixels ([On]).

### Notes

- When Native Scan is selected, 2K resolution signals are displayed while enlarged horizontally and vertically with the following proportion (repeating pixel values).
  - 1280 × 720 signal: × 3
  - Others: × 2
- 640 × 480/60P, 720 × 480/60P, and 720 × 576/50P signals for HDMI are not enlarged up to the end of the display.

### [Flicker Free]

Press the button to change the flicker free setting.

### [R Off]

Press the button to turn off the R (red) signal.

### [G Off]

Press the button to turn off the G (green) signal.

### [B Off]

Press the button to turn off the B (blue) signal.

### [User Preset1]

### [User Preset2]

### [User Preset3]

### [User Preset4]

### [User Preset5]

### [User Preset XYZ]

Press the button to change the User Preset number. You can check the setting status of the User Preset in the [User Preset Setting] menu (page 24).

### [Internal Signal]

Press the button to display the internal signal.

### [Internal Signal Pattern]

Press the button to change the pattern of the internal signal when the internal signal is displayed. With every press of the button, the picture switches to [PLUGE], [Gray], [White], [5 Step], [Ramp], and [Color Bars], in this order.

### [Gamut Marker]

Press the button to display the gamut marker.

### [Input Setting1]

### [Input Setting2]

### [Input Setting3]

### [Input Setting4]

Press the button so that the setting switches to the assigned input setting.

### [Marker]

Press the button to display the aspect marker, area marker 1, area marker 2 or center marker with the selected marker preset setting.

### [Aspect Marker]

Press the button to display the aspect marker.

### [Area Marker1]

Press the button to display area marker 1.

### [Area Marker2]

Press the button to display area marker 2.

### [Center Marker]

Press the button to display the center marker.

### [Aspect Marker-Line]

Press the button to display the line of the aspect marker.

### [Aspect Blanking-Half]

Press the button to set the aspect blanking to half.

### [Aspect Blanking-Black]

Press the button to set the aspect blanking to black.

### Note

The [Marker] to [Aspect Blanking-Black] settings are not available in the following cases:

- When the input signal is no sync signal
- When the internal signal is displayed
- When the screen saver is activated

### [In.Select/In.Setting]

Press the button to switch the input signal or set the input settings.

The [Input Select/Input Setting] menu is displayed when the button is pressed.

- **[Input Select]:** Select the input signal to monitor from [SDI1 4K], [SDI1 2K], [SDI2 4K], [SDI2 2K] or [HDMI].
- **[Input Setting]:** Set each signal input setting ([Input Setting1] to [Input Setting4]).

### [Audio Setting]

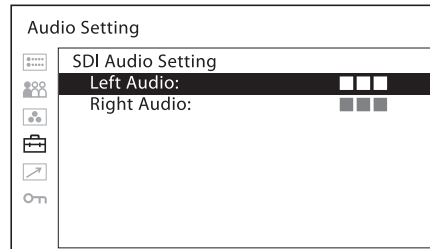

Submenu	Setting
[SDI Audio Setting]	Sets the audio channel when SDI signal is input. <ul style="list-style-type: none"> <li>• <b>[Left Audio]:</b> Select from channels [CH1] to [CH16].</li> <li>• <b>[Right Audio]:</b> Select from channels [CH1] to [CH16].</li> </ul> When a channel from [CH1] to [CH8] is selected in [Left Audio], you can select a channel from [CH1] to [CH8] in [Right Audio]. When a channel from [CH9] to [CH16] is selected in [Left Audio], you can select a channel from [CH9] to [CH16] in [Right Audio].

### [Internal Signal Setting]

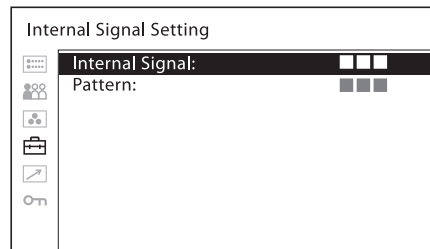



Submenu	Setting
[Internal Signal]	Select the internal signal display. <ul style="list-style-type: none"> <li>• [On]</li> <li>• [Off]</li> </ul>
[Pattern]	Select the pattern of the internal signal. <ul style="list-style-type: none"> <li>• [PLUGE]</li> <li>• [Gray]</li> <li>• [White]</li> <li>• [5 Step]</li> <li>• [Ramp]</li> <li>• [Color Bars]</li> </ul>

## [Gamut Marker Setting]

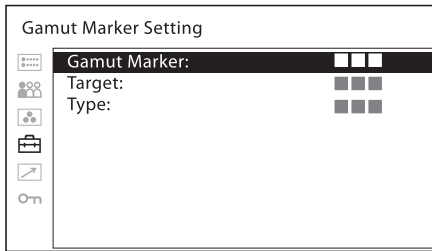

Submenu	Setting
[Gamut Marker]	Turns the gamut marker [On]/[Off]. The zebra pattern can be displayed for the signal outside of the targeted color space while [ITU-R BT.2020] is selected for [Color Space]. <ul style="list-style-type: none"> <li>• [On]: Displays the gamut marker.</li> <li>• [Off]: Disables the gamut marker function.</li> </ul>
[Target]	Sets the targeted color space. The zebra pattern can be displayed for the signal outside of the selected color space. <ul style="list-style-type: none"> <li>• [ITU-R BT.709]</li> <li>• [DCI-P3]</li> </ul>

### Notes

- The setting is available while [ITU-R BT.2020] is selected for [Color Space].
- The setting does not depend on the status of picture control functions such as contrast, chroma or white balance.
- When the input signal which is included the noise composition is over the targeted color space, the zebra pattern display may emphasize the noise.

[Type]	<ul style="list-style-type: none"> <li>• [Type1]: Displays the black zebra pattern.</li> <li>• [Type2]: Displays the black &amp; white zebra pattern.</li> </ul>
--------	--

## [Area and Aspect Marker Setting]

Switches the setting of marker.

To set on or off to the marker, assign the [Marker] function to the ASSIGN 1/2 button.

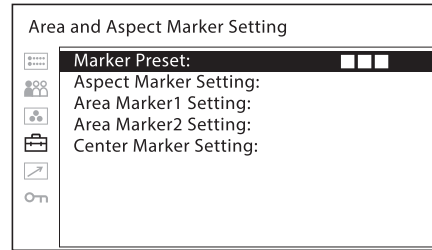

## [Marker Preset]

Displays the selected marker preset data.

## [Aspect Marker Setting]

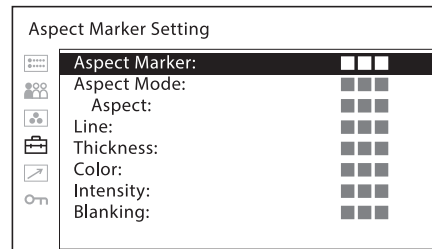





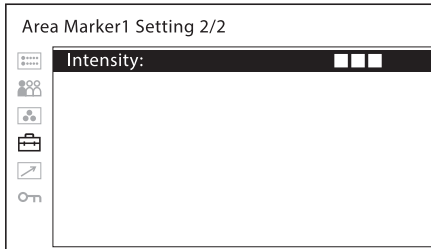
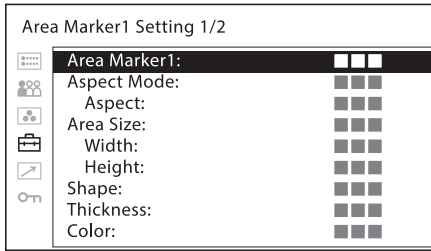

Submenu	Setting
[Aspect Marker]	Sets whether or not to display the aspect marker ([Off] or [On]).
[Aspect Mode]	Sets the aspect ratio of the aspect marker. You can select from [16:9], [15:9], [14:9], [13:9], [4:3], [2.39:1], [2.35:1], [1.85:1], [1.66:1], [1.896:1] or [Variable].
[Aspect]	Sets the aspect ratio of the aspect marker when [Variable] is selected in [Aspect Mode]. Set to 1.00:1 to 3.00:1. (Default value: [1.78]:1)
[Line]	Sets whether or not to display the line of the aspect marker ([Off] or [On]).
[Thickness]	Sets the thickness of the aspect marker. Set to 1 to 5 (dots). (Default value: [2])
[Color]	Sets the color of the aspect marker. You can select from [White] (white), [Red] (red), [Green] (green), [Blue] (blue), [Yellow] (yellow), [Cyan] (cyan) or [Magenta] (magenta).
[Intensity]	Sets the luminance of the aspect marker. You can select from [High] (bright) or [Low] (dark).
[Blanking]	Sets the blanking outside the area of the aspect marker. <ul style="list-style-type: none"> <li>• [Off]: Blanking is released.</li> <li>• [Black]: Sets blanking.</li> <li>• [Half]: Sets half blanking.</li> </ul>

## [Area Marker1 Setting]

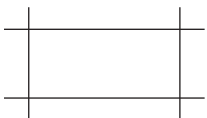

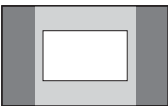
Submenu	Setting
[Area Marker1]	Sets whether or not to display area marker 1 ([Off] or [On]).
[Aspect Mode]	Sets the aspect ratio of area marker 1. You can select from [16:9], [15:9], [14:9], [13:9], [4:3], [2.39:1], [2.35:1], [1.85:1], [1.66:1], [1.896:1] or [Variable].
<b>Note</b>	
When [Variable(dots)] is selected in [Area Size], the size of area marker 1 is set in the pixels of the input signal and the [Aspect Mode] setting becomes invalid.	
[Aspect]	Sets the aspect ratio of area marker 1 when [Variable] is selected in [Aspect Mode]. Set to 1.00:1 to 3.00:1. (Default value: [1.78]:1)
[Area Size]	Sets the size of area marker 1. You can select from [80%], [88%], [90%], [93%], [Variable(%)] or [Variable(dots)].
[Width]	Sets the width of area marker 1 when [Area Size] is set to [Variable(%)] or [Variable(dots)]. <b>When [Variable(%)] is selected</b> Set to 050 to 100 (%). (Default value: [080]) <b>When [Variable(dots)] is selected</b> Set to 640 to 4096 (dots). Set one digit each. (Default value: [1024])

Submenu	Setting
[Height]	Sets the height of area marker 1 when [Area Size] is set to [Variable(%)] or [Variable(dots)]. <b>When [Variable(%)] is selected</b> Set to 050 to 100 (%). (Default value: [080]) <b>When [Variable(dots)] is selected</b> Set to 360 to 2160 (dots). Set one digit each. (Default value: [576])
[Shape]	Sets the shape of area marker 1. You can select from [Shape A], [Shape B] or [Shape C]. <ul style="list-style-type: none"> <li>[Shape A]                </li> <li>[Shape B]                </li> <li>[Shape C]                </li> </ul>
<b>Note</b>	
The size of the area differs depending on the [Aspect Mode] setting.	
<b>With 16:9</b>	
	
80% [Aspect Mode] is set to [16:9]	80% [Aspect Mode] is set to [4:3]
<b>With 4:3</b>	
	
80% [Aspect Mode] is set to [1.896:1]	80% [Aspect Mode] is set to [4:3]
[Thickness]	Sets the thickness of area marker 1. Set to 1 to 5 (dots). (Default value: [2])
[Color]	Sets the color of area marker 1. You can select from [White] (white), [Red] (red), [Green] (green), [Blue] (blue), [Yellow] (yellow), [Cyan] (cyan) or [Magenta] (magenta).

Submenu	Setting
[Intensity]	Sets the luminance of area marker 1. You can select from [High] (bright) or [Low] (dark).

### [Area Marker2 Setting]

Sets area marker 2. The set items are the same as for [Area Marker1 Setting].

### [Center Marker Setting]

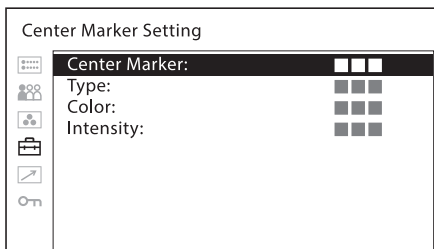

Submenu	Setting
[Center Marker]	Sets whether or not to display the center marker ([Off] or [On]).

[Type]

Sets the display mode of the center marker. You can select from [Type1], [Type2], or [Type3].

- [Type1]

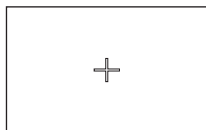

- [Type2]



- [Type3]

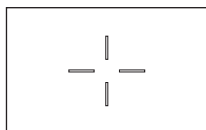

[Color]	Sets the color of the center marker. You can select from [White] (white), [Red] (red), [Green] (green), [Blue] (blue), [Yellow] (yellow), [Cyan] (cyan) or [Magenta] (magenta).
---------	---

[Intensity]	Sets the luminance of the center marker. You can select from [High] (bright) or [Low] (dark).
-------------	---

## [Quad View Setting]

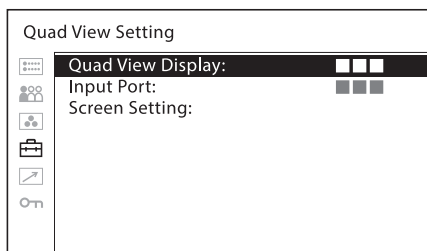

Submenu	Setting
[Quad View Display]	Sets the Quad View [On] or [Off].
[Input Port]	Select the input signal for Quad View. <ul style="list-style-type: none"> <li>[SDI1/HDMI]: Displays the 2K/HD signal input from the SDI 1 IN connector and HDMI IN connector.</li> <li>[SDI2/HDMI]: Displays the 2K/HD signal input from the SDI 2 IN connector and HDMI IN connector.</li> </ul>

## [Screen Setting]

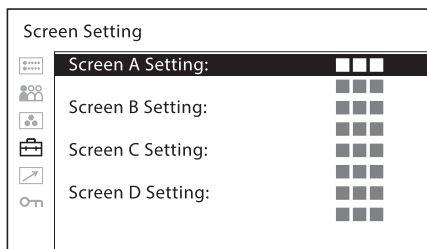

Submenu	Setting
[Screen A Setting] to [Screen D Setting]	Select the Input Setting and User Preset. <p>Input Setting</p> <ul style="list-style-type: none"> <li>[SDI 2K/HD In. Setting1]</li> <li>[SDI 2K/HD In. Setting2]</li> <li>[SDI 2K/HD In. Setting3]</li> <li>[SDI 2K/HD In. Setting4]</li> <li>[HDMI Input Setting1]</li> <li>[HDMI Input Setting2]</li> <li>[HDMI Input Setting3]</li> <li>[HDMI Input Setting4]</li> </ul> <p>User Preset</p> <ul style="list-style-type: none"> <li>[User Preset1]</li> <li>[User Preset2]</li> <li>[User Preset3]</li> <li>[User Preset4]</li> <li>[User Preset5]</li> </ul>

## About the Quad View setting

When Quad View is set to [On], the screen is divided into four parts.

Screen A	Screen B
Screen C	Screen D

### Notes

- The signal equivalent to HDMI/SDI 4K cannot be displayed with Quad View.
- Only one Input Setting per input terminal can be displayed simultaneously.  
Example: If [Input Setting1] and [Input Setting2] is set to the same SDI1 input connector 1, they cannot be displayed at same time. To compare the same image, input the image of input connector 1 to the other connector and set [Input Setting2] to the input connector.  
When a combination which cannot be displayed simultaneously is set, the screen which can be displayed is displayed in order from Screen A. The screen which cannot be displayed turns black and a message is displayed.
- The drive frequency of the panel changes to the same as Screen A.
- The combination of SDI 1 and SDI2 cannot be displayed with Quad View.
- [Native Scan] is set to [Off].
- The XYZ format signal is not supported.
- Set the same [RGB/YCC Range] settings for the all screens.
- Sets the same frame rate of the signal which is input to each screen for all screens.
- Set [Gamut Marker] and [Mono] to [Off].

The following settings are available with a combination of Input Setting and User Preset.

Screen A SDI1 INPUT1, HDR (BT.2020, S-Log3)	Screen B HDMI, SDR (BT709, 2.4)
Screen C SDI1 INPUT3, SDR (BT.2020, 2.4)	Screen D SDI1 INPUT4, HDR (BT.2020, ST 2084)

### [Serial Remote] menu

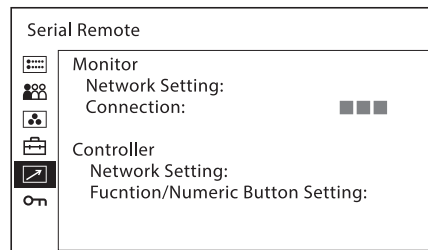

Submenu	Setting
[Monitor]	Sets the monitor setting.
[Network Setting]	<ul style="list-style-type: none"> <li>• <b>[Monitor ID]</b>: Sets the ID of the monitor.</li> <li>• <b>[Group ID]</b>: Sets the group ID of the monitor.</li> <li>• <b>[IP Address]</b>: Sets the IP address.</li> <li>• <b>[Subnet Mask]</b>: Sets the subnet mask. ([255.255.255.000])</li> <li>• <b>[Default Gateway]</b>: Sets the default gateway [On] or [Off].</li> <li>• <b>[Address]</b>: Sets the default gateway.</li> <li>• <b>[Cancel]</b>: Selects to cancel the setting.</li> <li>• <b>[Confirm]</b>: Selects to save the setting.</li> </ul>
[Connection]	Sets the connection of the monitor and the controller. <ul style="list-style-type: none"> <li>• <b>[Peer to Peer]</b>: for one to one connection</li> <li>• <b>[LAN]</b>: for connection via a network</li> </ul>
[Controller]	Sets the controller setting.
[Network Setting]	<ul style="list-style-type: none"> <li>• <b>[IP Address]</b>: Sets the IP address.</li> <li>• <b>[Subnet Mask]</b>: Sets the subnet mask. ([255.255.255.000])</li> <li>• <b>[Default Gateway]</b>: Sets the default gateway [On] or [Off].</li> <li>• <b>[Address]</b>: Sets the default gateway.</li> <li>• <b>[Cancel]</b>: Selects to cancel the setting.</li> <li>• <b>[Confirm]</b>: Selects to save the setting.</li> </ul>
[Function/Numeric Button Setting]	Set functions to be assigned to the F1 to F16 buttons and 1 to 9 buttons on the controller. <p><i>For the functions which are assigned to the F1 to F16 buttons of the controller, see page 15.</i></p> <p><i>For the functions which are assigned to the 1 to 9 buttons, see "About functions assigned to the ASSIGN 1/2 buttons" (page 33).</i></p> <p><i>However, you cannot assign the [In.Select/In.Setting] function.</i></p>

### Note

[Controller] menu is available when the menu is displayed via BKM-16R. (Only when BKM-16R is connected with the Peer to Peer connection or Single connection.)

## ☰ [Security] menu

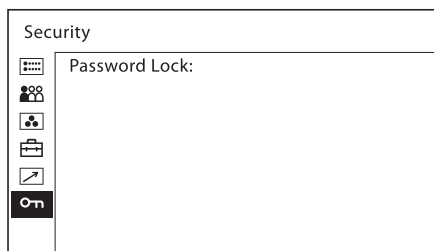

Submenu	Setting
[Password Lock]	<p>You can protect the setting with a password so that the settings saved in the color temperature for [User1] and the User Preset for [User Preset1] cannot be changed.</p> <p>When you protect the values with a password, set a four-digit number. The initial password is "0000". When you use [Password Lock], change the initial password first.</p> <ul style="list-style-type: none"> <li>• <b>[Color Temp./User Pre.]</b>: Select [On] to protect the setting values saved in the color temperature for [User1] and the User Preset for [User Preset1]. Select [Off] to not protect with the password.</li> <li>• <b>[Change Password]</b>: Changes the password.</li> </ul>

### Note

If you forget the password, refer to Sony qualified service personnel.

## Connecting the SDI Signals

Single Link 3G/HD-SDI, Dual Link 3G/HD-SDI, and Quad Link 3G/HD-SDI signals can be input to the SDI 1 IN and SDI 2 IN connectors of this unit.

Signals up to 4-channel Single Link 3G/HD-SDI signals, signals up to 2-channel Dual Link 3G/HD-SDI signals, or 1-channel Quad Link 3G/HD-SDI signals can be input to the SDI 1 IN connector and the SDI 2 IN connector respectively. Use the appropriate input connectors depending on the input signal, referring to the tables below.

### Connecting the Dual Link 3G/HD-SDI signal

Connector	Input signal
SDI IN <b>1</b>	3G/HD-SDI Link 1
SDI IN <b>2</b>	3G/HD-SDI Link 2

or

Connector	Input signal
SDI IN <b>3</b>	3G/HD-SDI Link 1
SDI IN <b>4</b>	3G/HD-SDI Link 2

When only 1-channel Dual Link 3G/HD-SDI signal is input, the Single Link 3G/HD-SDI signals of up to 2 channels can be input via the SDI IN connectors that are not used for the Dual Link 3G/HD-SDI signal.

### Connecting the Quad Link 3G/HD-SDI signal

#### To input 2-sample interleave division signals

Connector	Input signal
SDI IN <b>1</b>	3G-SDI Link 1
SDI IN <b>2</b>	3G-SDI Link 2
SDI IN <b>3</b>	3G-SDI Link 3
SDI IN <b>4</b>	3G-SDI Link 4

#### To input Square division signals

Connector	Input signal
SDI IN <b>1</b>	Mapping signal of Sub image 1 (upper-left screen)
SDI IN <b>2</b>	Mapping signal of Sub image 2 (upper-right screen)
SDI IN <b>3</b>	Mapping signal of Sub image 3 (lower-left screen)

Connector	Input signal
SDI IN [4]	Mapping signal of Sub image 4 (lower-right screen)

## Troubleshooting

This section may help you isolate the cause of a problem and as a result, eliminate the need to contact technical support.

- **The unit cannot be operated** → A function that does not work is assigned to the ASSIGN 1/2 button. Check the settings in the [Assign Button Setting] screen.
- **The black bars appear at the upper and lower or left and right positions of the display** → When the signal aspect ratio is different from that of the panel, the black bars appear. This is not a failure of the unit.
- **Adjustments and settings cannot be made** → Adjustments and settings may not be possible depending on the input signals and the status of the unit. See “Input Signals and Adjustable/Setting Items” (page 16).
- **The screen becomes dark and the unit turns off** → If the internal temperature of the unit increases, the screen may become dark and the unit may turn off. Check if the ventilation slots or vents are blocked with something such as dust.  
In this case, refer to Sony qualified service personnel.
- **Color is not displayed correctly** → Check the [Interface Format] display or the [Signal Format], [Color Temp.], or [Color Space] setting.
- **An afterimage is displayed** → An afterimage may be displayed depending on the input image. This is not a malfunction.

# Specifications

## Picture performance

Panel	OLED panel
Picture size (diagonal)	1387.8 mm (54.6 inches)
Effective picture size (H × V)	1209.6 × 680.4 mm (47 <sup>5</sup> / <sub>8</sub> × 26 <sup>7</sup> / <sub>8</sub> inches)
Resolution (H × V)	3840 × 2160 pixels
Aspect	16:9
Pixel efficiency	99.99%
Panel drive	10-bit
Viewing angle (Panel specification)	89°/89°/89°/89° (typical) (up/down/left/right, contrast > 10:1)
Scan	0% scan (fixed)
Color temperature	D65, D93, D61, D55, DCI
Standard luminance (100% white signal input)	100 cd/m <sup>2</sup> (User Preset1 – User Preset5) 48 cd/m <sup>2</sup> (User Preset XYZ)
Warm-up time	Approx. 30 minutes To provide stable picture quality, turn on the power of the monitor and leave it in this state for more than 30 minutes.

## Input

SDI 1 (3G/HD) input	BNC type (4) Input impedance: 75 Ω unbalanced
SDI 2 (3G/HD) input	BNC type (4) Input impedance: 75 Ω unbalanced
HDMI input	HDMI connector (1) HDCP 2.2
Serial remote (LAN)	RJ-45 modular connector (1) Ethernet (10BASE-T/100BASE-TX)

## Output

MONITOR (3G/HD) output	BNC type (4) Output impedance: 75 Ω unbalanced
SDI 2 (3G/HD) output	BNC type (4) Output impedance: 75 Ω unbalanced
Audio monitor output connector	Stereo mini jack (1)

## General

Power	AC 100 V to 240 V, 5.7 A to 2.3 A, 50/60 Hz
Power consumption	Approx. 500 W (max.) Approx. 290 W (average power consumption in the default status)
Operating conditions	Temperature 0 °C to 35 °C (32 °F to 95 °F) Recommended temperature 20 °C to 30 °C (68 °F to 86 °F) Humidity 30% to 85% (no condensation) Pressure 700 hPa to 1060 hPa
Storage and transport conditions	Temperature –20 °C to +60 °C (–4 °F to +140 °F) Humidity 0% to 90% Pressure 700 hPa to 1060 hPa
Accessories supplied	AC power cord (1) AC plug holder (1) HDMI cable holder (1) Monitor stand (2) Screw (8) Before Using This Unit (1) CD-ROM (1) European Representative (1)

Design and specifications are subject to change without notice.

### Notes

- Always verify that the unit is operating properly before use. SONY WILL NOT BE LIABLE FOR DAMAGES OF ANY KIND INCLUDING, BUT NOT LIMITED TO, COMPENSATION OR REIMBURSEMENT ON ACCOUNT OF THE LOSS OF PRESENT OR PROSPECTIVE PROFITS DUE TO FAILURE OF THIS UNIT, EITHER DURING THE WARRANTY PERIOD OR AFTER EXPIRATION OF THE WARRANTY, OR FOR ANY OTHER REASON WHATSOEVER.
- SONY WILL NOT BE LIABLE FOR CLAIMS OF ANY KIND MADE BY USERS OF THIS UNIT OR MADE BY THIRD PARTIES.
- SONY WILL NOT BE LIABLE FOR THE TERMINATION OR DISCONTINUATION OF ANY SERVICES RELATED TO THIS UNIT THAT MAY RESULT DUE TO CIRCUMSTANCES OF ANY KIND.

SONY WILL NOT BE LIABLE FOR DAMAGES OF ANY KIND RESULTING FROM A FAILURE TO IMPLEMENT PROPER SECURITY MEASURES ON TRANSMISSION DEVICES, UNAVOIDABLE DATA LEAKS RESULTING FROM TRANSMISSION SPECIFICATIONS, OR SECURITY PROBLEMS OF ANY KIND.

Depending on the operating environment, unauthorized third parties on the network may be able to access the unit. When connecting the unit to the network, be sure to confirm that the network is protected securely.

## Available Signal Formats

The unit is applicable to the following signal formats.

### 2K/HD (HD-SDI)

Signal System	Signal Structure	SDI 1	SDI 2
1920 × 1080/60I <sup>1)</sup>	4 : 2 : 2 (YCbCr) 10bit	○	○
1920 × 1080/50I	4 : 2 : 2 (YCbCr) 10bit	○	○
1920 × 1080/30P <sup>1)</sup>	4 : 2 : 2 (YCbCr) 10bit	○	○
1920 × 1080/30PsF <sup>1)</sup>	4 : 2 : 2 (YCbCr) 10bit	○	○
1920 × 1080/25P	4 : 2 : 2 (YCbCr) 10bit	○	○
1920 × 1080/25PsF	4 : 2 : 2 (YCbCr) 10bit	○	○
1920 × 1080/24P <sup>1)</sup>	4 : 2 : 2 (YCbCr) 10bit	○	○
1920 × 1080/24PsF <sup>1)</sup>	4 : 2 : 2 (YCbCr) 10bit	○	○
1280 × 720/60P <sup>1)</sup>	4 : 2 : 2 (YCbCr) 10bit	○	○
1280 × 720/50P	4 : 2 : 2 (YCbCr) 10bit	○	○
1280 × 720/30P <sup>1)</sup>	4 : 2 : 2 (YCbCr) 10bit	○	○
1280 × 720/25P	4 : 2 : 2 (YCbCr) 10bit	○	○
1280 × 720/24P <sup>1)</sup>	4 : 2 : 2 (YCbCr) 10bit	○	○
2048 × 1080/30P <sup>1)</sup>	4 : 2 : 2 (YCbCr) 10bit	○	○
2048 × 1080/30PsF <sup>1)</sup>	4 : 2 : 2 (YCbCr) 10bit	○	○
2048 × 1080/25P	4 : 2 : 2 (YCbCr) 10bit	○	○
2048 × 1080/25PsF	4 : 2 : 2 (YCbCr) 10bit	○	○
2048 × 1080/24P <sup>1)</sup>	4 : 2 : 2 (YCbCr) 10bit	○	○
2048 × 1080/24PsF <sup>1)</sup>	4 : 2 : 2 (YCbCr) 10bit	○	○

### 2K/HD (HD-SDI Dual Link)

Signal System	Signal Structure	SDI 1	SDI 2
1920 × 1080/60P <sup>1)</sup>	4 : 2 : 2 (YCbCr) 10bit	○	○
1920 × 1080/50P	4 : 2 : 2 (YCbCr) 10bit	○	○
1920 × 1080/60I <sup>1)</sup>	4 : 4 : 4 (RGB) 10bit	○	○
	4 : 4 : 4 (YCbCr) 10bit		
	4 : 4 : 4 (RGB) 12bit		
	4 : 4 : 4 (YCbCr) 12bit		
1920 × 1080/50I	4 : 4 : 4 (RGB) 10bit	○	○
	4 : 4 : 4 (YCbCr) 10bit		
	4 : 4 : 4 (RGB) 12bit		
	4 : 4 : 4 (YCbCr) 12bit		



Signal System	Signal Structure	SDI 1	SDI 2
1920 × 1080/30P <sup>1)</sup>	4 : 4 : 4 (RGB) 10bit	○	○
	4 : 4 : 4 (YCbCr) 10bit		
	4 : 4 : 4 (RGB) 12bit		
	4 : 4 : 4 (YCbCr) 12bit		
1920 × 1080/30PsF <sup>1)</sup>	4 : 4 : 4 (RGB) 10bit	○	○
	4 : 4 : 4 (YCbCr) 10bit		
	4 : 4 : 4 (RGB) 12bit		
	4 : 4 : 4 (YCbCr) 12bit		
1920 × 1080/25P	4 : 4 : 4 (RGB) 10bit	○	○
	4 : 4 : 4 (YCbCr) 10bit		
	4 : 4 : 4 (RGB) 12bit		
	4 : 4 : 4 (YCbCr) 12bit		
1920 × 1080/25PsF	4 : 4 : 4 (RGB) 10bit	○	○
	4 : 4 : 4 (YCbCr) 10bit		
	4 : 4 : 4 (RGB) 12bit		
	4 : 4 : 4 (YCbCr) 12bit		
1920 × 1080/24P <sup>1)</sup>	4 : 4 : 4 (RGB) 10bit	○	○
	4 : 4 : 4 (YCbCr) 10bit		
	4 : 4 : 4 (RGB) 12bit		
	4 : 4 : 4 (YCbCr) 12bit		
1920 × 1080/24PsF <sup>1)</sup>	4 : 4 : 4 (RGB) 10bit	○	○
	4 : 4 : 4 (YCbCr) 10bit		
	4 : 4 : 4 (RGB) 12bit		
	4 : 4 : 4 (YCbCr) 12bit		
2048 × 1080/60P <sup>1)</sup>	4 : 2 : 2 (YCbCr) 10bit	○	○
2048 × 1080/50P	4 : 2 : 2 (YCbCr) 10bit	○	○
2048 × 1080/48P <sup>1)</sup>	4 : 2 : 2 (YCbCr) 10bit	○	○
2048 × 1080/30P <sup>1)</sup>	4 : 4 : 4 (RGB) 10bit	○	○
	4 : 4 : 4 (YCbCr) 10bit		
	4 : 4 : 4 (RGB) 12bit		
	4 : 4 : 4 (YCbCr) 12bit		
2048 × 1080/30PsF <sup>1)</sup>	4 : 4 : 4 (RGB) 10bit	○	○
	4 : 4 : 4 (YCbCr) 10bit		
	4 : 4 : 4 (RGB) 12bit		
	4 : 4 : 4 (YCbCr) 12bit		
2048 × 1080/25P	4 : 4 : 4 (RGB) 10bit	○	○
	4 : 4 : 4 (YCbCr) 10bit		
	4 : 4 : 4 (RGB) 12bit		
	4 : 4 : 4 (YCbCr) 12bit		
2048 × 1080/25PsF	4 : 4 : 4 (RGB) 10bit	○	○
	4 : 4 : 4 (YCbCr) 10bit		
	4 : 4 : 4 (RGB) 12bit		
	4 : 4 : 4 (YCbCr) 12bit		

Signal System	Signal Structure	SDI 1	SDI 2
2048 × 1080/24P <sup>1)</sup>	4 : 4 : 4 (RGB) 10bit	○	○
	4 : 4 : 4 (YCbCr) 10bit		
	4 : 4 : 4 (RGB) 12bit		
	4 : 4 : 4 (YCbCr) 12bit		
2048 × 1080/24PsF <sup>1)</sup>	4 : 4 : 4 (RGB) 10bit	○	○
	4 : 4 : 4 (YCbCr) 10bit		
	4 : 4 : 4 (RGB) 12bit		
	4 : 4 : 4 (YCbCr) 12bit		
2048 × 1080/30P	4 : 4 : 4 (XYZ) 12bit	○	○
2048 × 1080/30PsF	4 : 4 : 4 (XYZ) 12bit	○	○
2048 × 1080/25P	4 : 4 : 4 (XYZ) 12bit	○	○
2048 × 1080/25PsF	4 : 4 : 4 (XYZ) 12bit	○	○
2048 × 1080/24P	4 : 4 : 4 (XYZ) 12bit	○	○
2048 × 1080/24PsF	4 : 4 : 4 (XYZ) 12bit	○	○

## 2K/HD (3G-SDI)

Signal System	Signal Structure	SDI 1	SDI 2
1920 × 1080/60P <sup>1)</sup>	4 : 2 : 2 (YCbCr) 10bit	○	○
1920 × 1080/50P	4 : 2 : 2 (YCbCr) 10bit	○	○
	4 : 4 : 4 (RGB) 10bit		
	4 : 4 : 4 (YCbCr) 10bit		
	4 : 4 : 4 (RGB) 12bit		
1920 × 1080/60I <sup>1)</sup>	4 : 4 : 4 (YCbCr) 10bit	○	○
	4 : 4 : 4 (RGB) 12bit		
	4 : 4 : 4 (YCbCr) 12bit		
	4 : 4 : 4 (RGB) 10bit		
1920 × 1080/50I	4 : 4 : 4 (YCbCr) 10bit	○	○
	4 : 4 : 4 (RGB) 12bit		
	4 : 4 : 4 (YCbCr) 12bit		
	4 : 4 : 4 (RGB) 10bit		
1920 × 1080/30P <sup>1)</sup>	4 : 4 : 4 (YCbCr) 10bit	○	○
	4 : 4 : 4 (RGB) 12bit		
	4 : 4 : 4 (YCbCr) 12bit		
	4 : 4 : 4 (RGB) 10bit		
1920 × 1080/30PsF <sup>1)</sup>	4 : 4 : 4 (YCbCr) 10bit	○	○
	4 : 4 : 4 (RGB) 12bit		
	4 : 4 : 4 (YCbCr) 12bit		
	4 : 4 : 4 (RGB) 10bit		
1920 × 1080/25P	4 : 4 : 4 (YCbCr) 10bit	○	○
	4 : 4 : 4 (RGB) 12bit		
	4 : 4 : 4 (YCbCr) 12bit		
	4 : 4 : 4 (RGB) 10bit		
1920 × 1080/25PsF	4 : 4 : 4 (YCbCr) 10bit	○	○
	4 : 4 : 4 (RGB) 12bit		
	4 : 4 : 4 (YCbCr) 12bit		
	4 : 4 : 4 (RGB) 12bit		

Signal System	Signal Structure	SDI 1	SDI 2
1920 × 1080/24P <sup>1)</sup>	4 : 4 : 4 (RGB) 10bit	○	○
	4 : 4 : 4 (YCbCr) 10bit		
	4 : 4 : 4 (RGB) 12bit		
	4 : 4 : 4 (YCbCr) 12bit		
1920 × 1080/24PsF <sup>1)</sup>	4 : 4 : 4 (RGB) 10bit	○	○
	4 : 4 : 4 (YCbCr) 10bit		
	4 : 4 : 4 (RGB) 12bit		
	4 : 4 : 4 (YCbCr) 12bit		
1280 × 720/60P <sup>1)</sup>	4 : 4 : 4 (RGB) 10bit	○	○
	4 : 4 : 4 (YCbCr) 10bit		
1280 × 720/50P	4 : 4 : 4 (RGB) 10bit	○	○
	4 : 4 : 4 (YCbCr) 10bit		
1280 × 720/30P <sup>1)</sup>	4 : 4 : 4 (RGB) 10bit	○	○
	4 : 4 : 4 (YCbCr) 10bit		
1280 × 720/25P	4 : 4 : 4 (RGB) 10bit	○	○
	4 : 4 : 4 (YCbCr) 10bit		
1280 × 720/24P <sup>1)</sup>	4 : 4 : 4 (RGB) 10bit	○	○
	4 : 4 : 4 (YCbCr) 10bit		
2048 × 1080/60P <sup>1)</sup>	4 : 2 : 2 (YCbCr) 10bit	○	○
2048 × 1080/50P	4 : 2 : 2 (YCbCr) 10bit	○	○
2048 × 1080/48P <sup>1)</sup>	4 : 2 : 2 (YCbCr) 10bit	○	○
2048 × 1080/30P <sup>1)</sup>	4 : 4 : 4 (RGB) 10bit	○	○
	4 : 4 : 4 (YCbCr) 10bit		
	4 : 4 : 4 (RGB) 12bit		
	4 : 4 : 4 (YCbCr) 12bit		
2048 × 1080/30PsF <sup>1)</sup>	4 : 4 : 4 (RGB) 10bit	○	○
	4 : 4 : 4 (YCbCr) 10bit		
	4 : 4 : 4 (RGB) 12bit		
	4 : 4 : 4 (YCbCr) 12bit		
2048 × 1080/25P	4 : 4 : 4 (RGB) 10bit	○	○
	4 : 4 : 4 (YCbCr) 10bit		
	4 : 4 : 4 (RGB) 12bit		
	4 : 4 : 4 (YCbCr) 12bit		
2048 × 1080/25PsF	4 : 4 : 4 (RGB) 10bit	○	○
	4 : 4 : 4 (YCbCr) 10bit		
	4 : 4 : 4 (RGB) 12bit		
	4 : 4 : 4 (YCbCr) 12bit		
2048 × 1080/24P <sup>1)</sup>	4 : 4 : 4 (RGB) 10bit	○	○
	4 : 4 : 4 (YCbCr) 10bit		
	4 : 4 : 4 (RGB) 12bit		
	4 : 4 : 4 (YCbCr) 12bit		
2048 × 1080/24PsF <sup>1)</sup>	4 : 4 : 4 (RGB) 10bit	○	○
	4 : 4 : 4 (YCbCr) 10bit		
	4 : 4 : 4 (RGB) 12bit		
	4 : 4 : 4 (YCbCr) 12bit		

Signal System	Signal Structure	SDI 1	SDI 2
2048 × 1080/30P	4 : 4 : 4 (XYZ) 12bit	○	○
2048 × 1080/30PsF	4 : 4 : 4 (XYZ) 12bit	○	○
2048 × 1080/25P	4 : 4 : 4 (XYZ) 12bit	○	○
2048 × 1080/25PsF	4 : 4 : 4 (XYZ) 12bit	○	○
2048 × 1080/24P	4 : 4 : 4 (XYZ) 12bit	○	○
2048 × 1080/24PsF	4 : 4 : 4 (XYZ) 12bit	○	○

### 2K/HD (3G-SDI Dual Link)

Signal System	Signal Structure	SDI 1	SDI 2
1920 × 1080/60P <sup>1)</sup>	4 : 4 : 4 (RGB) 10bit	○	○
	4 : 4 : 4 (YCbCr) 10bit		
	4 : 4 : 4 (RGB) 12bit		
	4 : 4 : 4 (YCbCr) 12bit		
1920 × 1080/50P	4 : 4 : 4 (RGB) 10bit	○	○
	4 : 4 : 4 (YCbCr) 10bit		
	4 : 4 : 4 (RGB) 12bit		
	4 : 4 : 4 (YCbCr) 12bit		
2048 × 1080/60P <sup>1)</sup>	4 : 4 : 4 (RGB) 10bit	○	○
	4 : 4 : 4 (YCbCr) 10bit		
	4 : 4 : 4 (RGB) 12bit		
	4 : 4 : 4 (YCbCr) 12bit		
2048 × 1080/50P	4 : 4 : 4 (RGB) 10bit	○	○
	4 : 4 : 4 (YCbCr) 10bit		
	4 : 4 : 4 (RGB) 12bit		
	4 : 4 : 4 (YCbCr) 12bit		
2048 × 1080/48P <sup>1)</sup>	4 : 4 : 4 (RGB) 10bit	○	○
	4 : 4 : 4 (YCbCr) 10bit		
	4 : 4 : 4 (RGB) 12bit		
	4 : 4 : 4 (YCbCr) 12bit		

### 4K/UHD (HD-SDI Quad Link)

Signal System	Signal Structure	SDI 1	SDI 2
3840 × 2160/30P <sup>1)</sup>	4 : 2 : 2 (YCbCr) 10bit	○	○
3840 × 2160/30PsF <sup>1)</sup>	4 : 2 : 2 (YCbCr) 10bit	○	○
3840 × 2160/25P	4 : 2 : 2 (YCbCr) 10bit	○	○
3840 × 2160/25PsF	4 : 2 : 2 (YCbCr) 10bit	○	○
3840 × 2160/24P <sup>1)</sup>	4 : 2 : 2 (YCbCr) 10bit	○	○
3840 × 2160/24PsF <sup>1)</sup>	4 : 2 : 2 (YCbCr) 10bit	○	○
4096 × 2160/30P <sup>1)</sup>	4 : 2 : 2 (YCbCr) 10bit	○	○
4096 × 2160/30PsF <sup>1)</sup>	4 : 2 : 2 (YCbCr) 10bit	○	○
4096 × 2160/25P	4 : 2 : 2 (YCbCr) 10bit	○	○
4096 × 2160/25PsF	4 : 2 : 2 (YCbCr) 10bit	○	○
4096 × 2160/24P <sup>1)</sup>	4 : 2 : 2 (YCbCr) 10bit	○	○
4096 × 2160/24PsF <sup>1)</sup>	4 : 2 : 2 (YCbCr) 10bit	○	○

## 4K/UHD (3G-SDI Dual Link)

Signal System	Signal Structure	SDI 1	SDI 2
3840 × 2160/30P <sup>1)</sup>	4 : 2 : 2 (YCbCr) 10bit Level B-DS <sup>2)</sup> Square/2SI	○	○
3840 × 2160/30PsF <sup>1)</sup>	4 : 2 : 2 (YCbCr) 10bit Level B-DS <sup>2)</sup> Square	○	○
3840 × 2160/25P	4 : 2 : 2 (YCbCr) 10bit Level B-DS <sup>2)</sup> Square/2SI	○	○
3840 × 2160/25PsF	4 : 2 : 2 (YCbCr) 10bit Level B-DS <sup>2)</sup> Square	○	○
3840 × 2160/24P <sup>1)</sup>	4 : 2 : 2 (YCbCr) 10bit Level B-DS <sup>2)</sup> Square/2SI	○	○
3840 × 2160/24PsF <sup>1)</sup>	4 : 2 : 2 (YCbCr) 10bit Level B-DS <sup>2)</sup> Square	○	○
4096 × 2160/30P <sup>1)</sup>	4 : 2 : 2 (YCbCr) 10bit Level B-DS <sup>2)</sup> Square/2SI	○	○
4096 × 2160/30PsF <sup>1)</sup>	4 : 2 : 2 (YCbCr) 10bit Level B-DS <sup>2)</sup> Square	○	○
4096 × 2160/25P	4 : 2 : 2 (YCbCr) 10bit Level B-DS <sup>2)</sup> Square/2SI	○	○
4096 × 2160/25PsF	4 : 2 : 2 (YCbCr) 10bit Level B-DS <sup>2)</sup> Square	○	○
4096 × 2160/24P <sup>1)</sup>	4 : 2 : 2 (YCbCr) 10bit Level B-DS <sup>2)</sup> Square/2SI	○	○
4096 × 2160/24PsF <sup>1)</sup>	4 : 2 : 2 (YCbCr) 10bit Level B-DS <sup>2)</sup> Square	○	○

## 4K/UHD (3G-SDI Quad Link)

Signal System	Signal Structure	SDI 1	SDI 2
3840 × 2160/60P <sup>1)</sup>	4 : 2 : 2 (YCbCr) 10bit Level A/Level B-DL Square/2SI	○	○
3840 × 2160/50P	4 : 2 : 2 (YCbCr) 10bit Level A/Level B-DL Square/2SI	○	○
3840 × 2160/30P <sup>1)</sup>	4 : 4 : 4 (RGB) 10bit	○	○
	4 : 4 : 4 (YCbCr) 10bit		
	4 : 4 : 4 (RGB) 12bit		
	4 : 4 : 4 (YCbCr) 12bit		
3840 × 2160/30PsF <sup>1)</sup>	4 : 4 : 4 (RGB) 10bit	○	○
	4 : 4 : 4 (YCbCr) 10bit		
	4 : 4 : 4 (RGB) 12bit		
	4 : 4 : 4 (YCbCr) 12bit		
3840 × 2160/25P	4 : 4 : 4 (RGB) 10bit	○	○
	4 : 4 : 4 (YCbCr) 10bit		
	4 : 4 : 4 (RGB) 12bit		
	4 : 4 : 4 (YCbCr) 12bit		
3840 × 2160/25PsF	4 : 4 : 4 (RGB) 10bit	○	○
	4 : 4 : 4 (YCbCr) 10bit		
	4 : 4 : 4 (RGB) 12bit		
	4 : 4 : 4 (YCbCr) 12bit		
3840 × 2160/24P <sup>1)</sup>	4 : 4 : 4 (RGB) 10bit	○	○
	4 : 4 : 4 (YCbCr) 10bit		
	4 : 4 : 4 (RGB) 12bit		
	4 : 4 : 4 (YCbCr) 12bit		
3840 × 2160/24PsF <sup>1)</sup>	4 : 4 : 4 (RGB) 10bit	○	○
	4 : 4 : 4 (YCbCr) 10bit		
	4 : 4 : 4 (RGB) 12bit		
	4 : 4 : 4 (YCbCr) 12bit		
4096 × 2160/60P <sup>1)</sup>	4 : 2 : 2 (YCbCr) 10bit Level A/Level B-DL Square/2SI	○	○
4096 × 2160/50P	4 : 2 : 2 (YCbCr) 10bit Level A/Level B-DL Square/2SI	○	○

Signal System	Signal Structure	SDI 1	SDI 2		
4096 × 2160/48P <sup>1)</sup>	4 : 2 : 2 (YCbCr) 10bit	Level A/Level B-DL	Square/2SI	○	○
	4 : 4 : 4 (RGB) 10bit				
4096 × 2160/30P <sup>1)</sup>	4 : 4 : 4 (YCbCr) 10bit	Level A/Level B-DL	Square/2SI	○	○
	4 : 4 : 4 (RGB) 12bit				
	4 : 4 : 4 (YCbCr) 12bit				
	4 : 4 : 4 (RGB) 10bit				
4096 × 2160/30PsF <sup>1)</sup>	4 : 4 : 4 (YCbCr) 10bit	Level A/Level B-DL	Square	○	○
	4 : 4 : 4 (RGB) 12bit				
	4 : 4 : 4 (YCbCr) 12bit				
	4 : 4 : 4 (RGB) 10bit				
4096 × 2160/25P	4 : 4 : 4 (YCbCr) 10bit	Level A/Level B-DL	Square/2SI	○	○
	4 : 4 : 4 (RGB) 12bit				
	4 : 4 : 4 (YCbCr) 12bit				
	4 : 4 : 4 (RGB) 10bit				
4096 × 2160/25PsF	4 : 4 : 4 (YCbCr) 10bit	Level A/Level B-DL	Square	○	○
	4 : 4 : 4 (RGB) 12bit				
	4 : 4 : 4 (YCbCr) 12bit				
	4 : 4 : 4 (RGB) 10bit				
4096 × 2160/24P <sup>1)</sup>	4 : 4 : 4 (YCbCr) 10bit	Level A/Level B-DL	Square/2SI	○	○
	4 : 4 : 4 (RGB) 12bit				
	4 : 4 : 4 (YCbCr) 12bit				
	4 : 4 : 4 (RGB) 10bit				
4096 × 2160/24PsF <sup>1)</sup>	4 : 4 : 4 (YCbCr) 10bit	Level A/Level B-DL	Square	○	○
	4 : 4 : 4 (RGB) 12bit				
	4 : 4 : 4 (YCbCr) 12bit				
	4 : 4 : 4 (RGB) 12bit				
4096 × 2160/30P	4 : 4 : 4 (XYZ) 12bit	Level A/Level B-DL	Square/2SI	○	○
4096 × 2160/30PsF	4 : 4 : 4 (XYZ) 12bit	Level A/Level B-DL	Square	○	○
4096 × 2160/25P	4 : 4 : 4 (XYZ) 12bit	Level A/Level B-DL	Square/2SI	○	○
4096 × 2160/25PsF	4 : 4 : 4 (XYZ) 12bit	Level A/Level B-DL	Square	○	○
4096 × 2160/24P	4 : 4 : 4 (XYZ) 12bit	Level A/Level B-DL	Square/2SI	○	○
4096 × 2160/24PsF	4 : 4 : 4 (XYZ) 12bit	Level A/Level B-DL	Square	○	○

1) Also compatible with 1/1.001.

2) When Square is selected (physically same when 2SI is selected).

## HDMI

Signal System	Signal Structure	HDMI
640 × 480/60P <sup>1)</sup>	4 : 4 : 4 (RGB) 12/10/8bit	○
	4 : 4 : 4 (YCbCr) 12/10/8bit	
	4 : 2 : 2 (YCbCr) 12bit	
720 × 480/60P <sup>1)</sup>	4 : 4 : 4 (RGB) 12/10/8bit	○
	4 : 4 : 4 (YCbCr) 12/10/8bit	
	4 : 2 : 2 (YCbCr) 12bit	
1280 × 720/60P <sup>1)</sup>	4 : 4 : 4 (RGB) 12/10/8bit	○
	4 : 4 : 4 (YCbCr) 12/10/8bit	
	4 : 2 : 2 (YCbCr) 12bit	

Signal System	Signal Structure	HDMI
1920 × 1080/60I <sup>1)</sup>	4 : 4 : 4 (RGB) 12/10/8bit	○
	4 : 4 : 4 (YCbCr) 12/10/8bit	
	4 : 2 : 2 (YCbCr) 12bit	
720 × 576/50P	4 : 4 : 4 (RGB) 12/10/8bit	○
	4 : 4 : 4 (YCbCr) 12/10/8bit	
	4 : 2 : 2 (YCbCr) 12bit	
1280 × 720/50P	4 : 4 : 4 (RGB) 12/10/8bit	○
	4 : 4 : 4 (YCbCr) 12/10/8bit	
	4 : 2 : 2 (YCbCr) 12bit	
1920 × 1080/50I	4 : 4 : 4 (RGB) 12/10/8bit	○
	4 : 4 : 4 (YCbCr) 12/10/8bit	
	4 : 2 : 2 (YCbCr) 12bit	
1920 × 1080/60P <sup>1)</sup>	4 : 4 : 4 (RGB) 12/10/8bit	○
	4 : 4 : 4 (YCbCr) 12/10/8bit	
	4 : 2 : 2 (YCbCr) 12bit	
1920 × 1080/50P	4 : 4 : 4 (RGB) 12/10/8bit	○
	4 : 4 : 4 (YCbCr) 12/10/8bit	
	4 : 2 : 2 (YCbCr) 12bit	
1920 × 1080/30P <sup>1)</sup>	4 : 4 : 4 (RGB) 12/10/8bit	○
	4 : 4 : 4 (YCbCr) 12/10/8bit	
	4 : 2 : 2 (YCbCr) 12bit	
1920 × 1080/25P	4 : 4 : 4 (RGB) 12/10/8bit	○
	4 : 4 : 4 (YCbCr) 12/10/8bit	
	4 : 2 : 2 (YCbCr) 12bit	
1920 × 1080/24P <sup>1)</sup>	4 : 4 : 4 (RGB) 12/10/8bit	○
	4 : 4 : 4 (YCbCr) 12/10/8bit	
	4 : 2 : 2 (YCbCr) 12bit	
2048 × 1080/60P <sup>1)</sup>	4 : 4 : 4 (RGB) 12/10/8bit	○
	4 : 4 : 4 (YCbCr) 12/10/8bit	
	4 : 2 : 2 (YCbCr) 12bit	
2048 × 1080/50P	4 : 4 : 4 (RGB) 12/10/8bit	○
	4 : 4 : 4 (YCbCr) 12/10/8bit	
	4 : 2 : 2 (YCbCr) 12bit	
2048 × 1080/48P	4 : 4 : 4 (RGB) 12/10/8bit	○
	4 : 4 : 4 (YCbCr) 12/10/8bit	
	4 : 2 : 2 (YCbCr) 12bit	
2048 × 1080/30P <sup>1)</sup>	4 : 4 : 4 (RGB) 12/10/8bit	○
	4 : 4 : 4 (YCbCr) 12/10/8bit	
	4 : 2 : 2 (YCbCr) 12bit	
2048 × 1080/25P	4 : 4 : 4 (RGB) 12/10/8bit	○
	4 : 4 : 4 (YCbCr) 12/10/8bit	
	4 : 2 : 2 (YCbCr) 12bit	
2048 × 1080/24P <sup>1)</sup>	4 : 4 : 4 (RGB) 12/10/8bit	○
	4 : 4 : 4 (YCbCr) 12/10/8bit	
	4 : 2 : 2 (YCbCr) 12bit	

Signal System	Signal Structure	HDMI
3840 × 2160/30P <sup>1) 2)</sup>	4 : 4 : 4 (RGB) 12/10/8bit <sup>3) 5)</sup>	○
	4 : 4 : 4 (YCbCr) 12/10/8bit <sup>3) 4)</sup>	
	4 : 2 : 2 (YCbCr) 12bit	
3840 × 2160/25P <sup>2)</sup>	4 : 4 : 4 (RGB) 12/10/8bit <sup>3) 5)</sup>	○
	4 : 4 : 4 (YCbCr) 12/10/8bit <sup>3) 4)</sup>	
	4 : 2 : 2 (YCbCr) 12bit	
3840 × 2160/24P <sup>1) 2)</sup>	4 : 4 : 4 (RGB) 12/10/8bit <sup>3) 5)</sup>	○
	4 : 4 : 4 (YCbCr) 12/10/8bit <sup>3) 4)</sup>	
	4 : 2 : 2 (YCbCr) 12bit	
4096 × 2160/30P <sup>1) 2)</sup>	4 : 4 : 4 (RGB) 12/10/8bit <sup>3) 5)</sup>	○
	4 : 4 : 4 (YCbCr) 12/10/8bit <sup>3) 4)</sup>	
	4 : 2 : 2 (YCbCr) 12bit	
4096 × 2160/25P <sup>2)</sup>	4 : 4 : 4 (RGB) 12/10/8bit <sup>3) 5)</sup>	○
	4 : 4 : 4 (YCbCr) 12/10/8bit <sup>3) 4)</sup>	
	4 : 2 : 2 (YCbCr) 12bit	
4096 × 2160/24P <sup>1) 2)</sup>	4 : 4 : 4 (RGB) 12/10/8bit <sup>3) 5)</sup>	○
	4 : 4 : 4 (YCbCr) 12/10/8bit <sup>3) 4)</sup>	
	4 : 2 : 2 (YCbCr) 12bit	
3840 × 2160/60P <sup>1) 2)</sup>	4 : 4 : 4 (RGB) 8bit <sup>3)</sup>	○
	4 : 4 : 4 (YCbCr) 8bit <sup>3)</sup>	
	4 : 2 : 2 (YCbCr) 12bit <sup>3)</sup>	
	4 : 2 : 0 (YCbCr) 8bit	
3840 × 2160/50P <sup>2)</sup>	4 : 4 : 4 (RGB) 8bit <sup>3)</sup>	○
	4 : 4 : 4 (YCbCr) 8bit <sup>3)</sup>	
	4 : 2 : 2 (YCbCr) 12bit <sup>3)</sup>	
	4 : 2 : 0 (YCbCr) 8bit	
4096 × 2160/60P <sup>1) 2)</sup>	4 : 4 : 4 (RGB) 8bit <sup>3)</sup>	○
	4 : 4 : 4 (YCbCr) 8bit <sup>3)</sup>	
	4 : 2 : 2 (YCbCr) 12bit <sup>3)</sup>	
	4 : 2 : 0 (YCbCr) 8bit	
4096 × 2160/50P <sup>2)</sup>	4 : 4 : 4 (RGB) 8bit <sup>3)</sup>	○
	4 : 4 : 4 (YCbCr) 8bit <sup>3)</sup>	
	4 : 2 : 2 (YCbCr) 12bit <sup>3)</sup>	
	4 : 2 : 0 (YCbCr) 8bit	
800 × 600/60P	4 : 4 : 4 (RGB) 12/10/8bit	○
	4 : 4 : 4 (YCbCr) 12/10/8bit	
	4 : 2 : 2 (YCbCr) 12bit	
1024 × 768/60P	4 : 4 : 4 (RGB) 12/10/8bit	○
	4 : 4 : 4 (YCbCr) 12/10/8bit	
	4 : 2 : 2 (YCbCr) 12bit	

1) Also compatible with the frame rate 1/1.001.

2) This signal is described as “equivalent to the 4K signal” in this manual.

3) [Enhanced Format] must be selected in the [HDMI Signal Format] menu (page 33). Also, when using this input signal, use the Premium High-Speed HDMI cable. (30P, 25P, 24P signals are only for the 4:4:4 RGB/YCbCr 10/12bit signal.)

4) The 4:4:4(YCbCr)12/10bit signal is displayed after converting to the 4:2:2(YCbCr)12/10bit signal.

5) The 4:4:4(RGB)12/10bit signal is displayed as a 4:4:4(RGB)8bit signal.



# Dimensions

## Front

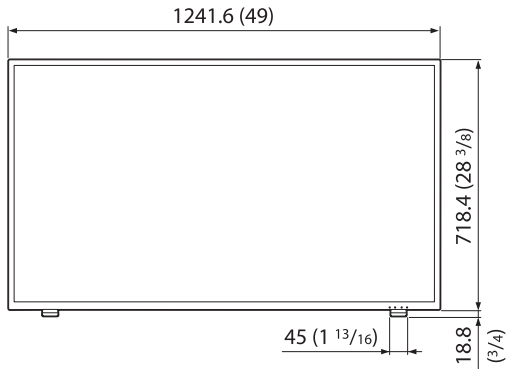

## Rear

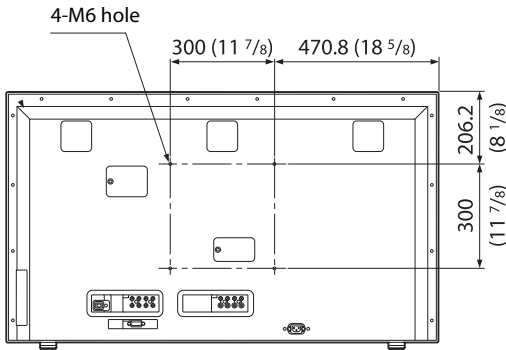

## Side

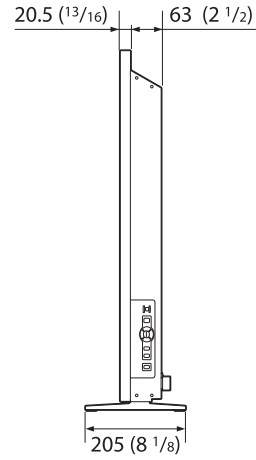

Unit: mm (inches)

Mass:

Approx. 21.7 kg (47 lb 13 oz)

### \* Length of M6 screws (rear)

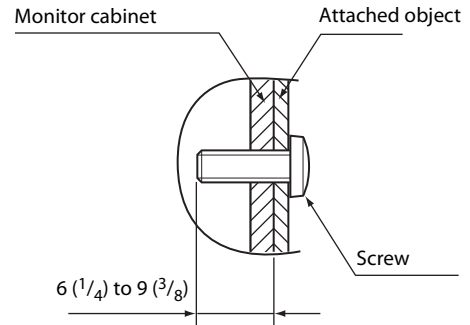

\* The specification of the screw is for the VESA mount.

### Notes

- Make sure to tighten the screws using the screwdriver which conforms to the supplied screws.
- When using an electric screwdriver, set the torque setting to approximately 1.5 N·m [15 kgf·cm].

Unit: mm (inches)

