

JVC

SERVICE MANUAL

COLOUR VIDEO MONITOR

BASIC CHASSIS

VL

TM-A14PN TM-A14PN-K

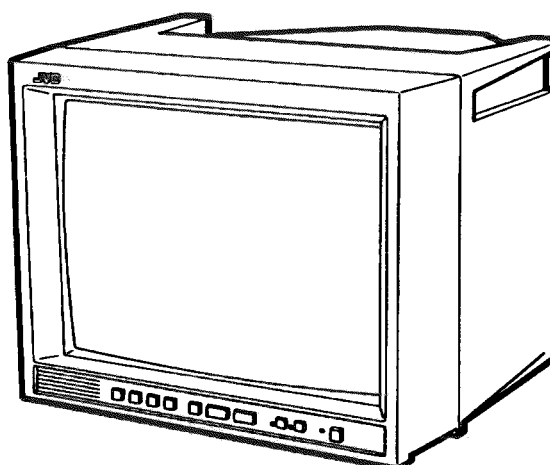

CONTENTS

■ SPECIFICATIONS	2
★ OPERATING INSTRUCTIONS (APPENDED)	1-1
■ SAFETY PRECAUTIONS	3
■ MAIN DIFFERENCE LIST	5
■ SPECIFIC SERVICE INSTRUCTIONS	6
■ SERVICE ADJUSTMENTS	12
★ STANDARD CIRCUIT DIAGRAM (APPENDED)	2-1
■ PARTS LIST	31

SPECIFICATIONS

Item	Content
Colour system Picture tube Effective screen size Scanning frequency Horizontal resolution	PAL / NTSC 3.58 36cm measured diagonally, flat square type, 90° deflection, in-line gun, vertical line trio type (phosphor stripe pitch 0.65 mm) 280.8mm × 210.6mm (W × H) / 335.4mm (Diagonal) (H) 15.734 kHz (NTSC) 15.625 kHz (PAL) (V) 59.94 Hz (NTSC) 50Hz (PAL) 320TV line or more (Y/C input mode)
High Voltage	24.0kV~26.0kV
Input / Output Composite video signal Y/C Separate (1line) Audio	INPUT A,B(2lines) : BNC × 2each (with 1 bridge-connected output) With automatic termination 1Vp-p 75 Ω Mini-DIN 4pin with automatic termination Y: 1.0Vp-p 75 Ω C: 0.286Vp-p 75 Ω (NTSC) 0.3Vp-p 75 Ω (PAL) AUDIO A, B : RCA × 2each Monaural 0.5Vrms, high-impedance (with 1 bridge-connection output)
Audio power output Speaker	1W (Monaural) 8cm round × 1 8 Ω
Power requirements Power consumption Operation temperature Operation humidity	230V AC, 50/60 Hz 0.53A maximum 0~40°C 20~80% (non-condensing)
Dimension Mass	368mm × 310mm × 371.5mm (W × H × D) 9.4kg

Design & specification are subject to change without notice.

OPERATING INSTRUCTIONS [TM-A14PN-K]

JVC

COLOUR VIDEO MONITOR

TM-A14PN-K

INSTRUCTIONS

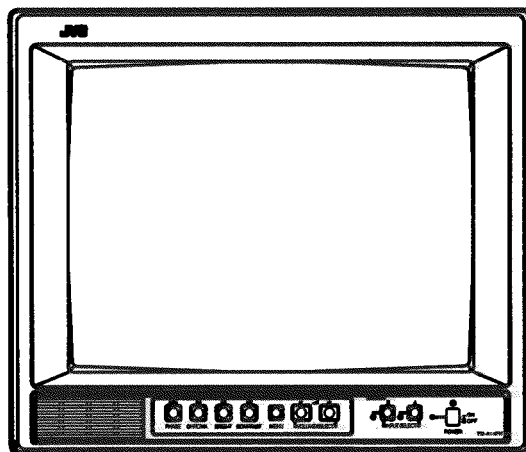

Thank you for purchasing this JVC colour video monitor. Before using it, read and follow all instructions carefully to take full advantage of the monitor's capabilities.

SAFETY PRECAUTIONS

In order to prevent any fatal accidents caused by misoperation or mishandling the monitor, be fully aware of all the following precautions.

WARNINGS
To prevent fire or shock hazard, do not expose this monitor to rain or moisture. Dangerous high voltages are present inside the unit. Do not remove the back cover of the cabinet. When servicing the monitor, contact qualified service personnel. Never try to service it yourself.

Machine Noise Information Ordinance 3, GSGV, January 18, 1991: The sound pressure level at the operator position is equal or less than 70 dB(A) according to ISO 7779.

WARNING : THIS APPARATUS MUST BE EARTHED.

PRECAUTIONS

- Use only the power source specified on the unit.
- When not using this unit for a long period of time, or when cleaning it, be sure to disconnect the power plug from the AC outlet.
- Do not allow anything to rest on the power cord. And do not place this unit where people will tread on the cord.
- Do not overload wall outlets or power cords as this can result in a fire or electric shock.
- Avoid using this unit under the following conditions:
 - in extremely hot, cold or humid places,
 - in dusty places,
 - near appliances generating strong magnetic fields,
 - in places subject to direct sunlight,
 - in badly ventilated places,
 - in automobiles with doors closed
- Do not cover the ventilation slots while in operation as this could obstruct the required ventilation flow.
- When dust accumulates on the screen surface, clean it with a soft cloth.
- Unplug this unit from the AC outlet and refer servicing to qualified service personnel under the following conditions:

- when the power cord is frayed or the plug is damaged,
- if liquid has been spilled into the unit,
- if the unit has been dropped or the cabinet has been damaged,
- when the unit exhibits a distinct change in performance.
- Do not attempt to service this unit yourself as opening or removing covers may expose you to dangerous voltage or other hazards. Always refer servicing to qualified service personnel.
- When replacement parts are required, have the service personnel verify in writing that the replacement parts he/she uses have the same safety characteristics as the original parts. Use of manufacturer's specified replacement parts can prevent fire, shock, or other hazards.
- Upon completion of any servicing or repair work to this unit, please ask the service personnel to perform the safety check described in the manufacturer's service literature.
- When this unit reaches the end of its useful life, improper disposal could result in a picture tube implosion. Ask qualified service personnel to dispose of this unit.

SCREEN BURN

- It is not recommended to keep a certain still image displayed on screen for a long time as well as displaying extremely bright images on screen. This may cause a burning (sticking) phenomenon on the screen of cathode-ray tubes. This problem does not occur as far as displaying normal video playback motion images.

POWER CONNECTION

WARNING

Do not cut off the main plug from this equipment. If the plug fitted is not suitable for the power points in your home or the cable is too short to reach a power point, then obtain an appropriate safety approved extension lead or adaptor or consult your dealer.

If nonetheless the mains plug is cut off, remove the fuse and dispose of the plug immediately, to avoid a possible shock hazard by inadvertent connection to the main supply.

If a new main plug has to be fitted, then follow the instruction given below.

WARNING:

THIS APPARATUS MUST BE EARTHED.

IMPORTANT:

The wires in the mains lead on this product are coloured in accordance with the following code:

- Green-and-yellow : Earth
- Blue : Neutral
- Brown : Live

As these colours may not correspond with the coloured making identifying the terminals in your plug, proceed as follows:

The wire which is coloured green-and-yellow must be connected to the terminal which is marked with the letter E or the safety earth symbol ⊕ or coloured green or green-and-yellow.

The wire which is coloured blue must be connected to the terminal which is marked with the letter N or coloured black.

The wire which is coloured brown must be connected to the terminal which is marked with the letter L or coloured red.

When replacing the fuse, be sure to use only a correctly rated approved type, re-fit the fuse cover.

IF IN DOUBT — CONSULT A COMPETENT ELECTRICIAN.

How To Replace The Fuse

Open the fuse compartment with the blade screwdriver, and replace the fuse.

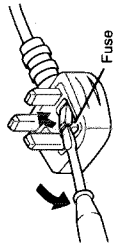

CONTENTS

SAFETY PRECAUTIONS	2
CONTROLS AND FEATURES	4
HOW TO HANDLE BASIC OPERATIONS	6
HOW TO USE THE MENU FUNCTIONS	7
HOW TO INITIALIZE THE SETTING	10
BASIC CONNECTION EXAMPLE	11
TROUBLESHOOTING	12
SPECIFICATIONS	13

CONTROLS AND FEATURES

FRONT VIEW

<Front Panel>

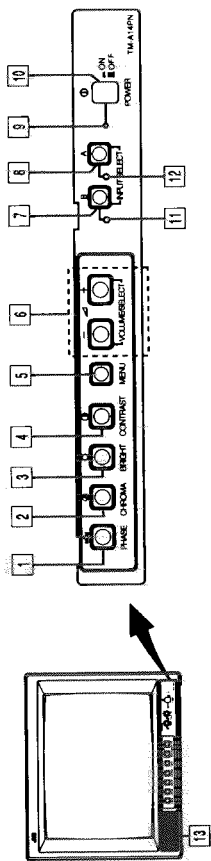

- 1 Phase button [PHASE]**
Press this button to set the picture hue adjustment mode. Adjust the value with the VOLUME/SELECT buttons. Also used as a control button in the menu function mode.
- 2 Chroma button [CHROMA]**
Press this button to set the picture colour density adjustment mode. Adjust the value with the VOLUME/SELECT buttons. Also used as a control button in the menu function mode.
- 3 Brightness button [BRIGHT]**
Press this button to adjust picture brightness. Adjust the value with the VOLUME/SELECT buttons. Also used as a control button in the menu function mode.
- 4 Contrast button [CONTRAST]**
Press this button to adjust picture contrast. Adjust the value with the VOLUME/SELECT buttons. Also used as a control button in the menu function mode.
- 5 Menu button [MENU]**
Displays and disappears the <MENU> screen. Pressing the PHASE button with the Menu button depressed will display the <SET-UP MENU> screen.
- 6 Volume/Select buttons [VOLUME/SELECT - +]**
Adjusts the speaker volume. Also used as a control button in the menu function mode.
- 7 Input B button [INPUT SELECT B]**
Selects the video signal input to the VIDEO B terminal and the audio signal input to the AUDIO B terminal (RCA connector) on the rear panel. When selected, the input B indicator [11] lights.
- 8 Input A button [INPUT SELECT A]**
Selects the video signal input to the VIDEO A terminal (BNC connector) and the audio signal input to the AUDIO A terminal (RCA connector) on the rear panel. When selected, the input A indicator [12] lights.
- 9 Power indicator**
Lights in green when the power is ON.
Lk : When the power is on.
Unit : When the power is off.
- 10 Power switch [POWER]**
Press this switch to turn the power on or off.
- ON : Power is turned on.
- OFF : Power is turned off.
- 11 Input B indicator**
Lights in green when the Input B is selected.
- 12 Input A indicator**
Lights in green when the Input A is selected.
- 13 Built-in speaker**
The speaker is located inside.

Note:

* The VIDEO B terminals include a video terminal (BNC connector) and a Y/C terminal (mini-DIN 4-pin connector). The Y/C (S-video) terminal is given priority.

REAR VIEW

<Rear Panel>

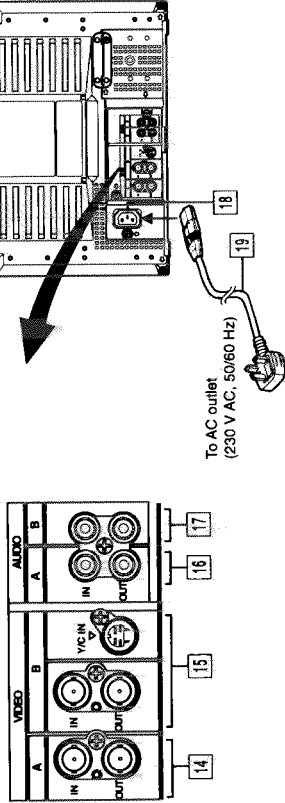

- 14 Video A terminals [VIDEO A IN/OUT]**
Video signal input (IN) and output (OUT) terminals. The output terminal is bridge-connected.
IN : Video signal input terminal
OUT : Bridge-connected video signal output terminal
Notes:
* For corresponding audio signals, use the AUDIO A terminals [16].
* Also refer to the Basic connection Example on page 11.
- 15 Video B terminals [VIDEO B IN/OUT] [BNC connector]**
Video signal input (IN) and output (OUT) terminals. The output terminal is bridge-connected.
IN : Video signal input terminal
OUT : Bridge-connected video signal output terminal
[Y/C connector]
Y/C (S-Video) signal input (mini-DIN 4-pin connector) terminal.
Y/C IN : Y/C signal input terminal.
Notes:
* For corresponding audio signals, use the AUDIO B terminals [17].
* There is no Y/C (S-video) signal output terminal.
* When both VIDEO B terminals are connected (input) at the same time, the Y/C terminal is given priority.
* Also refer to the Basic connection Example on page 11.
- 16 Audio A terminal [AUDIO A IN/OUT]**
Input (IN) and output (OUT) terminals for the audio signal corresponding the VIDEO A terminals [14]. The output terminal is bridge-connected.
IN : Audio signal input terminal
OUT : Bridge-connected audio signal output terminal
Notes:
* For corresponding video signals, use the VIDEO A terminal [14].
* Also refer to the Basic connection Example on page 11.
- 17 Audio B terminals [AUDIO B IN/OUT]**
Input (IN) and output (OUT) terminals for the audio signals corresponding to the VIDEO B terminals [15]. The output terminal is bridge-connected.
IN : Audio signal input terminal
OUT : Bridge-connected audio signal output terminal
Notes:
* For corresponding video signals, use the VIDEO B terminals [15].
* Also refer to the Basic connection Example on page 11.
- 18 AC inlet [AC IN]**
Power input connector. Connect the provided AC power cord [19] to an AC outlet (230 V AC, 50/60 Hz).
- 19 Power cord**
Connects the provided power cord (230 V AC, 50/60 Hz) to the AC IN connector.

To AC outlet
(230 V AC, 50/60 Hz)

HOW TO HANDLE BASIC OPERATIONS

BASIC OPERATION

1. Press the POWER switch to turn on the power.

- ON : Power turns ON. (Power indicator: lit)
- OFF : Power turns OFF. (Power indicator: unit)

2. Press the INPUT SELECT button to choose input.

Selects video/audio signals input to terminals on the rear panel.

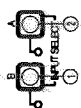

INPUT SELECT button	Video signal input	Audio signal input
① Input A	VIDEO A terminal	AUDIO A terminal
② Input B	VIDEO B terminal	AUDIO B terminal

3. Press the VOLUME/SELECT button to adjust the speaker volume.

Press this button to display the speaker volume level on the screen.
 + : The Built-in speaker volume is increased. (00 → 50)
 - : The Built-in speaker volume is decreased. (50 → 00)
 * Screen indication will disappear about 10 seconds after operating.



Colour system indication (PAL or NTSC)

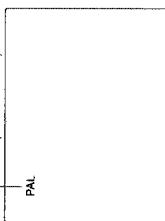

With regard to Colour system indication

- With the COLOR SYSTEM setting set to AUTO mode, when you turn on the power or select inputs, the colour system indication appears for about 3 seconds on the screen while PAL or NTSC signals are being detected. It does not appear when receiving B/W signal or when no signal is input. See page 7 for COLOR SYSTEM setting.

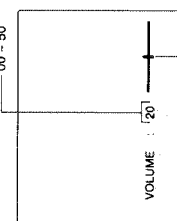

PICTURE ADJUSTMENT

1. Press select button corresponding to the item you want to adjust.

The item you select is displayed on the screen.

- ① PHASE (⊕) : Phase control
- ② CHROMA (⊗) : Chroma control
- ③ BRIGHT (⊙) : Brightness control
- ④ CONTRAST (⊕) : Contrast control

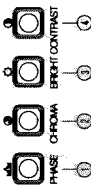

2. Adjust with the VOLUME/SELECT button.

Items	VOLUME/SELECT button	Contents
PHASE (Phase)	+	greenish
CHROMA (Chroma)	-	reddish
BRIGHT (Brightness)	+	lighter
BRIGHT (Brightness)	-	deeper
CONTRAST (Contrast)	+	lighter
CONTRAST (Contrast)	-	deeper
	+	brighter
	-	higher

* Screen indication will disappear about 10 seconds after operating.

HOW TO USE THE MENU FUNCTIONS DISPLAY AND SELECTION IN THE <MENU> SCREEN MODE (SETTING)

You can set the following menu items.

- SHARPNESS
- COLOR SYSTEM

1. Press the MENU button.



The <MENU> screen is displayed.

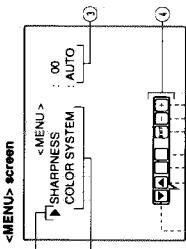

2. Press the PHASE (⊕) or CHROMA (⊗) button to select MENU items.

A selection mark (▶) is put next to the selected item.



Front panel button	Function displayed	Contents
PHASE (⊕)	▶	Advance selection mark (▶)
CHROMA (⊗)	▲	Reverse selection mark (◀)

- ① Selection mark (▶): Indicates the menu item you select.
- ② Menu Item: Menu items you can select.

- ③ Setting display: Indicates the current setting (value).
- ④ Function display: The functions of the front panel buttons (7 buttons on the left) correspond to the function displayed.

3. Press the VOLUME/SELECT button to set.



Front panel button	Function displayed	Contents
VOLUME/SELECT (+)	+	Increase (to max. value)
VOLUME/SELECT (-)	-	Advance the setting value
VOLUME/SELECT (-)	-	Decrease (to min. value)
VOLUME/SELECT (-)	◀	Reverse the setting value

Menu Items	Purpose	Setting range
SHARPNESS	Picture sharpness	00 ↔ +1 ↔ +2 ↔ +3 ↔ +4 ↔ +5
COLOR SYSTEM	Colour system	AUTO ↔ NTSC ↔ PAL

* Normally set the COLOR SYSTEM to the AUTO mode. If reception in the AUTO mode is not good, set it to the exclusive mode (NTSC or PAL) corresponding to the received colour system.

4. If you want to set the other menu items, repeat procedures 2 and 3.

5. Press the MENU button to quit.



Front panel button	Function displayed	Contents
MENU	EXIT	Quit (or Release) the <MENU> screen

Notes:

- Phase control is effective only in the NTSC colour system mode.
- Chroma control is not effective when receiving B/W or when no signal is input.
- When the Chroma control is set to level " -20", the picture turns monochrome.
- " NO EFFECT " is displayed for about 3 seconds when your selected function has no effect.

HOW TO USE THE MENU FUNCTIONS (cont'd)

DISPLAY AND SELECTIONS IN THE <SET-UP MENU> MODE (SETTING)

You can set the following set-up menu items.

- H. POSITION
- WHITE BALANCE
- CONTROL LOCK

Note:

- Parameters for H. POSITION can be set separately depending on the video input (input A or input B) selected by the input select buttons on the front panel. Select the required video input with the input select buttons on the front panel in advance.

1. While pressing the MENU button, press the PHASE () button.

The <SET-UP MENU> screen is displayed.



2. Press the PHASE () or CHROMA () button to select the desired menu item.

A selection mark (▶) is put next to the selected item.

Front panel button	Function displayed	Contents
PHASE ()	▶	Advance selection mark (▶)
CHROMA ()	◀	Reverse selection mark (◀)

3. Press the VOLUME/SELECT button to set.

Front panel button	Function displayed	Contents
VOLUME/SELECT (+)	+	Increase (to max. value)
VOLUME/SELECT (-)	-	Decrease (to min. value)
	▶	Advance the setting value
	◀	Reverse the setting value
	CUTO	Selects CUTO OFF setting screen
	DRV	Selects DRIVE setting screen

Notes:

- For the WHITE BALANCE setting, select the CUTO OFF or DRIVE setting screen, then select the buttons (PHASE/CHROMA/BRIGHT) corresponding to the function indicated (R/G/B).
- To return to the <SET-UP MENU> screen, press the EXIT (MENU) button.

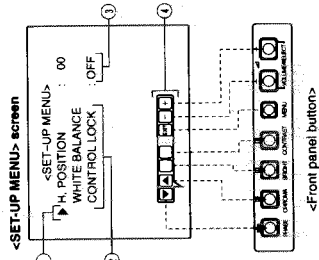

- ① Selection mark (▶): Indicates the menu item you select.
- ② Menu item: Menu items you can select.
- ③ Setting display: Indicates the current settings (value).
- ④ Function display: The functions on the front panel buttons (7 buttons on the left), correspond to the function displayed.

Function displayed	Contents
▶	Advance the menu item.
◀	Reverse the menu item.
-	Lower the adjustment value. (to the minimum)
+	Raise the adjustment value. (to the maximum)
▶	Advance the setting value.
◀	Reverse the setting value.
EXIT	Exit the <SET-UP MENU> screen (release)
DRV	Selects DRV adjustment
CUTO	Selects CUTO OFF adjustment
R	Adjusts red signal level
G	Adjusts green signal level
B	Adjusts blue signal level
DISP	Turns the ON-SCREEN display on or off. (This function is effective only in the DRIVE or CUTO OFF adjustment mode.)

Set-up menu items	Purpose	Settings
H. POSITION	Adjusts the horizontal position of the screen (+: Horizontal position shifts to the right/-: Horizontal position shifts to the left)	-05 ↔ -04 ↔ ... ↔ -01 ↔ 00 ↔ +01 ↔ ... ↔ +04 ↔ +05
WHITE BALANCE	Adjusts the white balance	Selects DRIVE (DRV) or CUTO OFF (CUTO) adjustment. Screen setting is changed to the selected setting mode. Select R/G/B buttons corresponding to the function display to adjust.
DRIVE R. DRIVE	Adjusts red level	-09 ↔ -08 ↔ ... ↔ -01 ↔ 00 ↔ +01 ↔ ... ↔ +08 ↔ +09
B. DRIVE	Adjusts blue level	-09 ↔ -08 ↔ ... ↔ -01 ↔ 00 ↔ +01 ↔ ... ↔ +08 ↔ +09
CUTO OFF R. CUTO OFF	Adjusts red cut off	-09 ↔ -08 ↔ ... ↔ -01 ↔ 00 ↔ +01 ↔ ... ↔ +08 ↔ +09
G. CUTO OFF	Adjusts green cut off	-09 ↔ -08 ↔ ... ↔ -01 ↔ 00 ↔ +01 ↔ ... ↔ +08 ↔ +09
B. CUTO OFF	Adjusts blue cut off	-09 ↔ -08 ↔ ... ↔ -01 ↔ 00 ↔ +01 ↔ ... ↔ +08 ↔ +09
CONTROL LOCK	Sets the operation buttons on the front panel to control lock mode	OFF ↔ ON

4. To set the other set-up menu items, repeat the procedures 2 and 3.

5. Press the MENU button to quit.



Front panel button	Function displayed	Contents
MENU	EXIT	Quit (or Release) the <MENU> screen

Notes:

- When the CONTROL LOCK function is set to ON, pressing operation buttons on the front panel will display the message "CONTROL LOCK ON!" on the screen for about 3 seconds.
- The CONTROL LOCK function is maintained even when the power is turned off.
- To turn off the CONTROL LOCK function, while holding the MENU button, press the PHASE button. Then set the CONTROL LOCK function to OFF.
- Even when the CONTROL LOCK function is set to ON, the following operations are available.
 - Power-Switch operation.
 - Sound volume adjustment with the VOLUME/SELECT button.
 - Display or disappear of the <SET-UP MENU> screen.

HOW TO INITIALIZE THE SETTING

SCREEN DISPLAY AND SELECTIONS IN THE <SET-UP MENU> RESET MODE

You can set <MENU> and <SET-UP MENU> screen items, picture adjustment items and the volume level to their factory-set (initial) values.

1. Press the Power (⏻) Switch to turn the power OFF (■).



2. While pressing both MENU button and PHASE (Ⓜ) switch to turn the power ON (■).

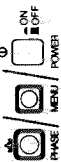

The <SET-UP MENU> RESET screen is displayed.

(Note:)

- The <SET-UP MENU> RESET screen will not be displayed if the MENU or PHASE buttons are pressed for a very short time. Keep pressing them until the display screen appears.

3. Setting

● Initialization is required.



Press the CONTRAST (Ⓜ) button.

- When initialization is completed, and the <SET-UP MENU> RESET screen disappears.

● Initialization is not required.



Press the VOLUME/SELECT (+) or (-) button.

- Initialization is aborted, and the <SET-UP MENU> RESET screen disappears.

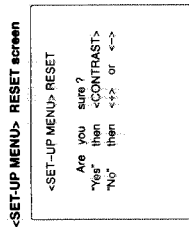

Functions (Items)	Initialization (setting)
SHARPNESS	00
COLOR SYSTEM	AUTO
H. POSITION	00
WHITE BALANCE	00
R. CUT OFF	00
G. CUT OFF	00
B. CUT OFF	00
R. DRIVE	00
B. DRIVE	00
CONTROL LOCK	OFF
PHASE	00
CHROMA	00
CONTRAST	00
BRIGHT	00
VOLUME	20

BASIC CONNECTION EXAMPLE

Notes:

- Before connecting your system, make sure that all units are turned off.
- The illustration below shows some examples of different connections. Terminal connections may differ, depending on the component connected. Be sure to refer to the instructions provided with the unit(s) you are connecting.
- Each pair of input (IN) and output (OUT) terminals are bridge-connected. However, the Y/C input terminal (Y/C IN) has no output terminal (OUT) corresponding to it.
- If you're not connecting any equipment to a bridged output (OUT) terminal, be sure not to connect any other cables to the bridged output (OUT) terminal as this will cause the terminating resistance switch to open (auto terminate function).
- When making a bridge connection, connect the input (IN) and output (OUT) terminals on the monitor to separate video components.
- For example, if both terminals are connected to the same VCR, resonances may occur except during playback. This is caused by the same video signal "looping" between the VCRs, and is not a malfunction.)
- Select the video input (Input A or Input B) with the input select button on the front panel.

VIDEO A Connection Example (Select Input A button)

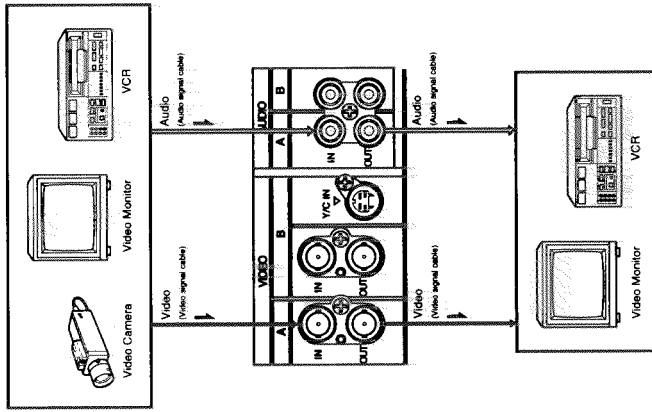

VIDEO B Connection Example (Select Input B button)

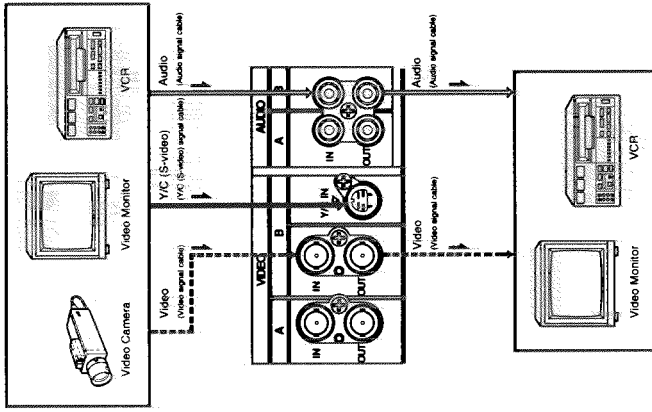

TROUBLESHOOTING

Solutions to common problems related to your monitor are described here. If none of the solutions presented here solves the problem, unplug the monitor and consult a JVC-authorized dealer or service center for assistance.

Problems	Points to be checked	Measures (Remedy)
No power supply.	Is the power plug loosened or disconnected?	Firmly insert the power plug.
No picture with the power on.	Is the video signal output from the connected component?	Set the connected component correctly.
	Is the input signal selected properly?	Select the required video signal input with the Input select button. (See page 6.)
No sound.	Is the video cable disconnected?	Connect the video signal cable firmly. (See page 11.)
	Is the audio signal output from the connected component?	Set the connected component correctly.
	Is the volume output set to minimum?	Adjust the speaker volume with the VOLUME/SELECT button. (See page 6.)
Shaking picture.	Is the audio cable disconnected?	Connect the audio signal cable firmly. (See page 11.)
	Is the monitor close to a device generating a strong magnetic field?	Move the device away from the monitor until the picture stabilizes.
No colours, wrong colour, or dark picture.	Is the colour system selected properly?	Set the COLOR SYSTEM in the <MENU> screen mode to [AUTO] mode. (See page 7.)
	Has the picture control setting (CONTRAST, BRIGHT, CHROMA or PHASE) been changed?	Set each picture control to the standard setting. (See page 6.)
Unnatural, irregularly coloured, or distorted picture.	Is the monitor close to a speaker, magnet or any other device generating a strong magnetic field?	Move the device away from the monitor and turn the monitor's power off. Wait at least 30 minutes, then turn the power on again.
Front panel button does not function.	Are the operation buttons on the front panel locked? (Has CONTROL LOCK function set to ON?)	Set the CONTROL LOCK to OFF in the <SET-UP MENU> screen mode. (See pages 8 and 9.)

The following are not malfunctions:

- When a bright still image (such as a white cloth) is displayed for a long period, it may appear to be coloured. This is due to the structure of the cathode ray tube and will be deleted when another image is displayed.
- You experience a mild electric shock when you touch the picture tube. This phenomenon is due to a normal buildup of static electricity on the CRT and is not harmful.
- The monitor emits a strange sound when the room temperature changes suddenly. This is only a problem if an abnormality appears on the screen as well.

SPECIFICATIONS

MODEL	TM-A14PN-K
Colour system	Colour video monitor PAL, NTSC (3:58)
Picture tube	36 cm measured diagonally, 90° deflection, in-line gun, vertical line trio type (phosphor stripe pitch 0.65 mm)
Effective screen size	Width 280.8 mm Height 210.6 mm Diagonal 335.4 mm
Scanning frequency	H : 15.734 kHz (NTSC), 15.625 kHz (PAL) V : 59.94 Hz (NTSC), 50 Hz (PAL)
Horizontal resolution	320 TV lines or more (Y/C input mode)
Input terminals	VIDEO A
	VIDEO B
AUDIO A	AUDIO B
	AUDIO B
Audio power output	1 W (monaural)
Built-in speaker	8 cm round x 1, impedance of 8 Ω
Environmental conditions	Operation temperature: 0 – 40 °C Operation humidity: 20 – 80% (non-condensing)
Power requirements	230 V AC, 50/60 Hz (Operating 120 – 230 V AC, 50/60 Hz)
Power consumption	0.53 A (230 V AC)
Dimensions	Width 368 mm
	Height 310 mm
	Depth 371.5 mm
Weight	9.4 kg
Accessory	AC power cord (2 m) x 1

* Illustrations used in this manual are for explanatory purposes only. The appearance of the actual product may differ slightly.

* Dimensions and weight are approximate.

* E. & O. E. Design and specifications subject to change without notice.

■ **Dimensions**

Unit : mm

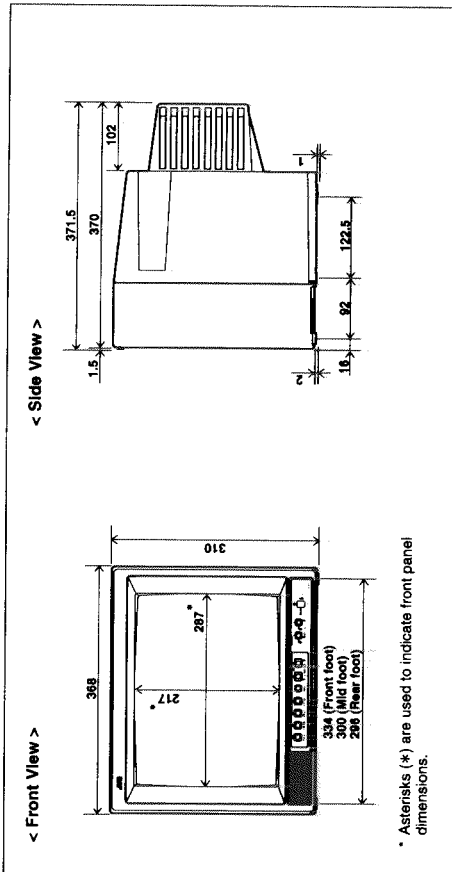

■ **Y/C (Mini DIN 4 pin) terminal specification**



Pin No.	Signal
1	GND (Y)
2	GND (C)
3	Y
4	C



© 1988 VICTOR COMPANY OF JAPAN, LIMITED

Printed in Scotland
LCT0068-001A-U
0198-TU-U-JMUK

SAFETY PRECAUTIONS [TM-A14PN]

- The design of this product contains special hardware, many circuits and components specially for safety purposes. For continued protection, no changes should be made to the original design unless authorized in writing by the manufacturer. Replacement parts must be identical to those used in the original circuits. Service should be performed by qualified personnel only.
- Alterations of the design or circuitry of the products should not be made. Any design alterations or additions will void the manufacturer's warranty and will further relieve the manufacturer of responsibility for personal injury or property damage resulting therefrom.
- Many electrical and mechanical parts in the products have special safety-related characteristics. These characteristics are often not evident from visual inspection nor can the protection afforded by them necessarily be obtained by using replacement components rated for higher voltage, wattage, etc. Replacement parts which have these special safety characteristics are identified in the parts list of Service manual. **Electrical components having such features are identified by shading on the schematics and by (Δ) on the parts list in Service manual.** The use of a substitute replacement which does not have the same safety characteristics as the recommended replacement part shown in the parts list of Service manual may cause shock, fire, or other hazards.
- Don't short between the LIVE side ground and ISOLATED (NEUTRAL) side ground or EARTH side ground when repairing.**
Some model's power circuit is partly different in the GND. The difference of the GND is shown by the LIVE : (\perp) side GND, the ISOLATED(NEUTRAL) : (\downarrow) side GND and EARTH : (\oplus) side GND. Don't short between the LIVE side GND and ISOLATED(NEUTRAL) side GND or EARTH side GND and never measure with a measuring apparatus (oscilloscope etc.) the LIVE side GND and ISOLATED(NEUTRAL) side GND or EARTH side GND at the same time.
If above note will not be kept, a fuse or any parts will be broken.
- If any repair has been made to the chassis, it is recommended that the B1 setting should be checked or adjusted (See ADJUSTMENT OF B1 POWER SUPPLY).
- The high voltage applied to the picture tube must conform with that specified in Service manual. Excessive high voltage can cause an increase in X-Ray emission, arcing and possible component damage, therefore operation under excessive high voltage conditions should be kept to a minimum, or should be prevented. If severe arcing occurs, remove the AC power immediately and determine the cause by visual inspection (incorrect installation, cracked or melted high voltage harness, poor soldering, etc.). To maintain the proper minimum level of soft X-Ray emission, components in the high voltage circuitry including the picture tube must be the exact replacements or alternatives approved by the manufacturer of the complete product.
- Do not check high voltage by drawing an arc. Use a high voltage meter or a high voltage probe with a VTVM. Discharge the picture tube before attempting meter connection, by connecting a clip lead to the ground frame and connecting the other end of the lead through a 10k Ω 2W resistor to the anode button.
- When service is required, observe the original lead dress. Extra precaution should be given to assure correct lead dress in the high voltage circuit area. Where a short circuit has occurred, those components that indicate evidence of overheating should be replaced. Always use the manufacturer's replacement components.

9. Isolation Check

(Safety for Electrical Shock Hazard)

After re-assembling the product, always perform an isolation check on the exposed metal parts of the cabinet (antenna terminals, video/audio input and output terminals, Control knobs, metal cabinet, screwheads, earphone jack, control shafts, etc.) to be sure the product is safe to operate without danger of electrical shock.

(1) Dielectric Strength Test

The isolation between the AC primary circuit and all metal parts exposed to the user, particularly any exposed metal part having a return path to the chassis should withstand a voltage of 3000V AC (r.m.s.) for a period of one second.

(... Withstand a voltage of 1100V AC (r.m.s.) to an appliance rated up to 120V, and 3000V AC (r.m.s.) to an appliance rated 200V or more, for a period of one second.)

This method of test requires a test equipment not generally found in the service trade.

(2) Leakage Current Check

Plug the AC line cord directly into the AC outlet (do not use a line isolation transformer during this check). Using a "Leakage Current Tester", measure the leakage current from each exposed metal part of the cabinet, particularly any exposed metal part having a return path to the chassis, to a known good earth ground (water pipe, etc.). Any leakage current must not exceed 0.5mA AC (r.m.s.).

However, in tropical area, this must not exceed 0.2mA AC (r.m.s.).

● Alternate Check Method

Plug the AC line cord directly into the AC outlet (do not use a line isolation transformer during this check). Use an AC voltmeter having 1000 ohms per volt or more sensitivity in the following manner. Connect a 1500 Ω 10W resistor paralleled by a 0.15 μ F AC-type capacitor between an exposed metal part and a known good earth ground (water pipe, etc.). Measure the AC voltage across the resistor with the AC voltmeter. Move the resistor connection to each exposed metal part, particularly any exposed metal part having a return path to the chassis, and measure the AC voltage across the resistor. Now, reverse the plug in the AC outlet and repeat each measurement. Any voltage measured must not exceed 0.75V AC (r.m.s.). This corresponds to 0.5mA AC (r.m.s.).

However, in tropical area, this must not exceed 0.3V AC (r.m.s.). This corresponds to 0.2mA AC (r.m.s.).

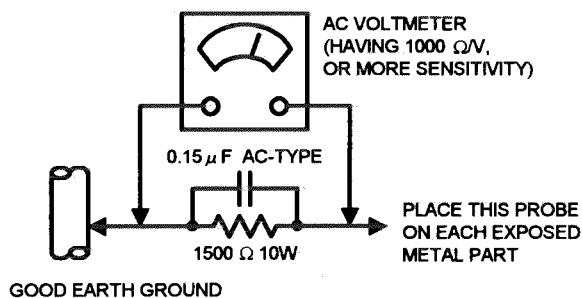



SAFETY RECAUTIONS [TM-A14PN-K]

1. The design of this product contains special hardware and many circuits and components specially for safety purposes. For continued protection, no changes should be made to the original design unless authorized in writing by the manufacturer. Replacement parts must be identical to those used in the original circuits. Service should be performed by qualified personnel only.
2. Alterations of the design or circuitry of the product should not be made. Any design alterations or additions will void the manufacturer's warranty and will further relieve the manufacturer of responsibility for personal injury or property damage resulting therefrom.
3. Many electrical and mechanical parts in the product have special safety-related characteristics. These characteristics are often not evident from visual inspection nor can the protection afforded by them necessary be obtained by using replacement components rated for higher voltage, wattage, etc. Replacement parts which have these special safety characteristics are identified in the Parts List of Service Manual. Electrical components having such features are identified by shading on the schematics and by (Δ) on the Parts List in the Service Manual. The use of a substitute replacement which does not have the same safety characteristics as the recommended replacement part shown in the Parts List of Service Manual may cause shock, fire, or other hazards.
4. The leads in the products are routed and dressed with ties, clamps, tubing's, barriers and the like to be separated from live parts, high temperature parts, moving parts and / or sharp edges for the prevention of electric shock and fire hazard. When service is required, the original lead routing and dress should be observed, and it should be confirmed that they have been returned to normal, after re-assembling.

WARNING

1. The equipment has been designed and manufactured to meet international safety standards.
2. It is the legal responsibility of the repairer to ensure that these safety standards are maintained.
3. Repairs must be made in accordance with the relevant safety standards.
4. It is essential that safety critical components are replaced by approved parts.
5. If mains voltage selector is provided, check setting for local voltage.

MAIN DIFFERENCE LIST

△	PARTS No.		PARTS NAME	Description
	TM-A14PN	TM-A14PN-K		
△	AEM2045-001-E	AEM2041-003-E	RATING LABEL	EXPLODED VIEW PARTS LIST
△	QMPL040-200-JC 	QMPP010-200-JC 	POWER CORD	PACKING PARTS LIST
	AEM1038-071-E	AEM1038-072-E	EURO LABEL	PACKING PARTS LIST
△	LCT0068-001A-U	LCT0069-001A-U	INST BOOK	PACKING PARTS LIST
	LC20037-001A-U	x	X-RAY CARD	PACKING PARTS LIST

SPECIFIC SERVICE INSTRUCTIONS

DISASSEMBLY PROCEDURE

[CAUTION]

- * Even with the power switch off, some parts of the set are live. Be sure to disconnect the power cord from the AC outlet before disassembly and reassembly.

REMOVING THE REAR COVER

1. Remove the 8 screws marked (A) as shown in the figure.
2. Withdraw the rear cover toward you.

REMOVING THE PW BOARD

- Remove the rear cover.
1. Slightly raise the both sides of the PW board by hand and remove the claw under the terminal bracket from the front cabinet.
 2. Withdraw the PW board backward.
(If necessary, take off the wire clamp, connectors etc.)

REMOVING THE TERMINAL BRACKET

- Remove the rear cover.
1. Remove the 4 screws marked (B).
 2. Withdraw the terminal bracket rearward.

REMOVING THE SPEAKER

- Remove the PW board.
1. Remove the claw securing the speaker under the front cabinet and pull out the speaker (Fig.1).

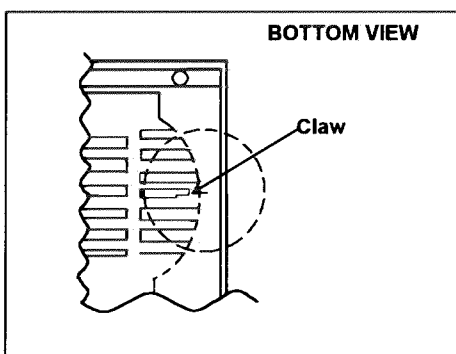

Fig. 1

CHECKING THE PW BOARD

To check the back side of the PW board.

- (1) Pull out the PW board.
- (2) Erect the chassis vertically so that you can easily check the back side of the PW board.

[CAUTION]

- * When erecting the PW board, be careful so that there will be no contacting with other PW board.

- * Before turning on power, make sure that the CRT earth wire and other connectors are properly connected.

WIRE CLAMPING AND CABLE TYING

1. Be sure to clamp the wire.
2. Never remove the cable tie used for tying the wires together. Should it be inadvertently removed, be sure to tie the wires With a new cable tie.

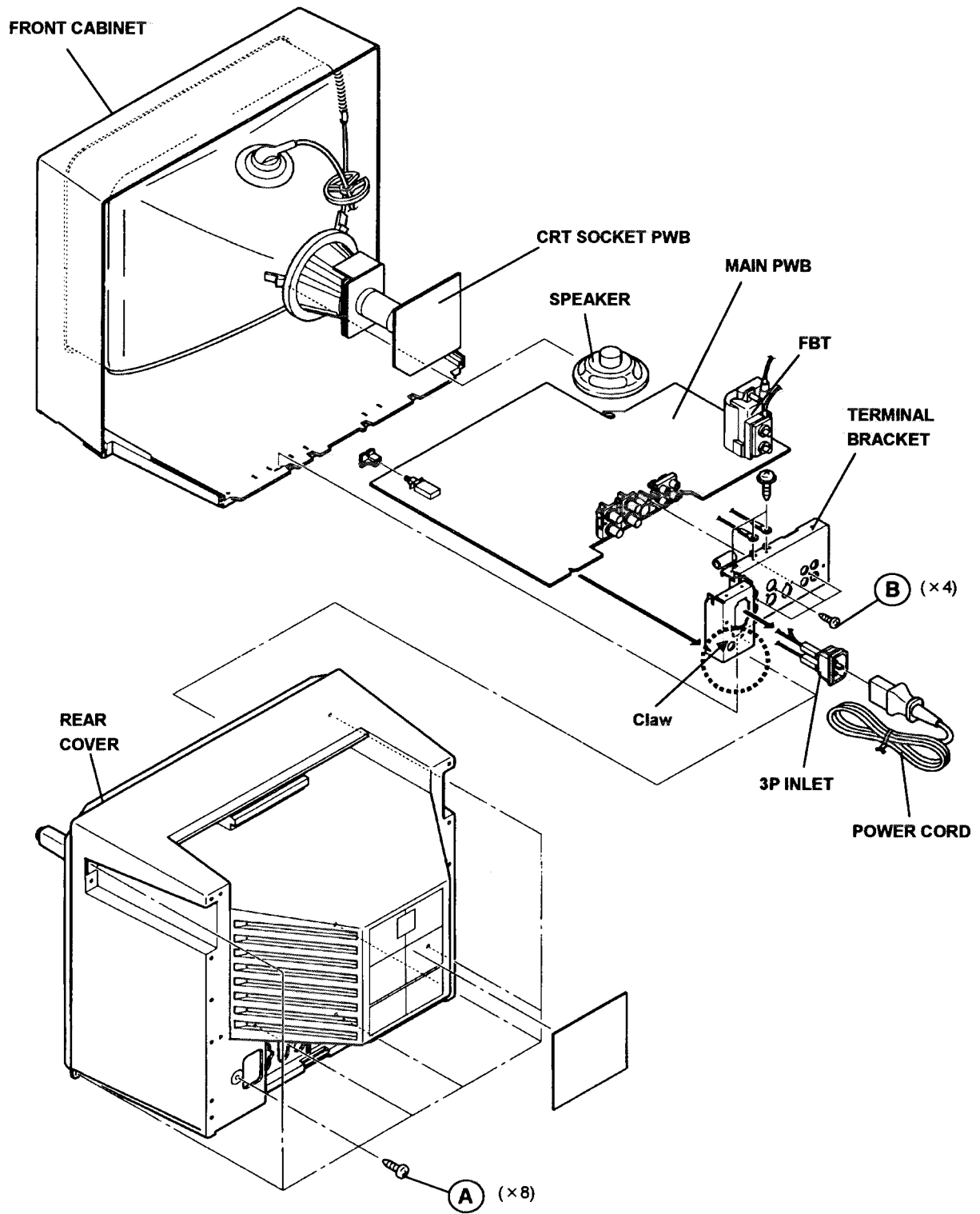

MEMORY IC REPLACEMENT NOTES

MEMORY IC

This model uses a memory IC (EEP-ROM ICs). In the memory IC are memorized data for correctly operating the video and deflection. The micro computer provides a function by which the initial setting values are entered into the memory IC. Therefore, when replacing the memory IC, a memory without initial setting values can be used. If the memory IC is replaced, the data must be entered into the new memory IC as described below.

PROCEDURE FOR REPLACING MEMORY IC

(1) Power off

Switch the power off and unplug the power code from the wall outlet.

(2) Replace IC

(3) Enter the data into new memory IC

- 1) When the power is turned on, the DATA LOAD screen as shown in Fig.1 will be displayed.
- 2) Press the <CONTRAST> button on the front panel of the cabinet.
- 3) The screen as shown in Fig.2 will be displayed.
- 4) Press the <- (Down)> button on the front side of the cabinet. The data will be entered into the memory IC.

(4) CONTROL DATA Change

* After changing the MEMORY IC, change the control data.

- 1) Enter into the SERVICE MENU. (Refer to the BASIC OPERATION OF THE SERVICE MENU.)
- 2) Select the CONTROL BLOCK and change the setting values in the following items.

[Note]

Don't change the data in other items unless otherwise required.

Service Number	SETTING VALUES	
	PREVIOUS	NEW
C22	013	017
C36	002	004

DATA LOAD MENU SCREEN

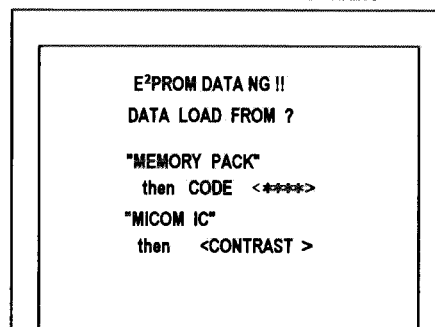

Fig.1

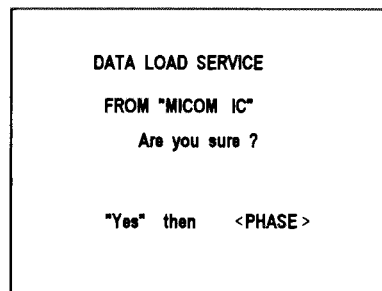

Fig.2

(5) Check and set SET-UP MENU

- 1) Press <MENU> and <PHASE> button simultaneously. The SET-UP MENU screen of Fig.3 will be displayed.
- 2) Check the values of SET-UP MENU by referring to the table 1 given below. If there is any discrepancy of the values, set the correct values with the button according to the display on the screen.

SET-UP SETTING VALUES

SETTING ITEMS		INITIAL SETTING VALUES
H.POSITION		00
WHITE BALANCE	CUTOFF(R/G/B)	00
	DRIVE(R/B)	00
CONTROL LOCK		OFF

Table 1

SET-UP MENU SCREEN

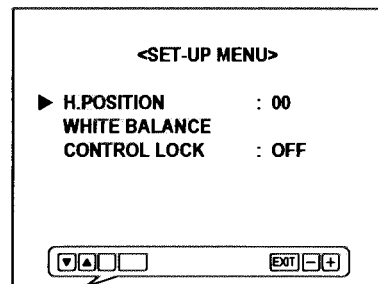

Fig.3

(6) Check and set MENU

- 1) Press <MENU> button. The MENU screen of Fig.4 will be displayed.
- 2) Check the values of MENU refer to the table 2. If there is any discrepancy of the values, set the correct values with the button according to the display on the screen.

MENU SETTING VALUES

SETTING ITEMS	INITIAL SETTING VALUES
SHARPNESS	00
COLOR SYSTEM	AUTO

Table 2

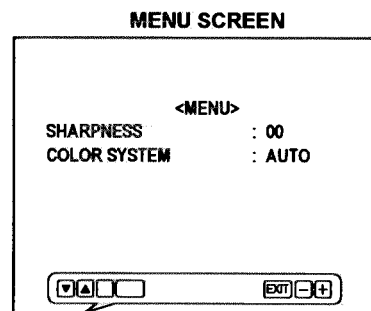

Fig.4

(7) Check and set FRONT CONTROL SETTING VALUES

- 1) Press the front panel button (CONTRAST, BRIGHT, CHROMA, PHASE). THE FRONT CONTROL SETTING screen Fig.5 will be displayed.
- 2) Check the values of FRONT CONTROL SETTING refer to Table 3. If there is any discrepancy of the values, Set the initial setting values <+ with <- > or > button directly.

FRONT CONTROL SETTING VALUES

SETTING ITEMS	INITIAL SETTING VALUES
CONTRAST	00
BRIGHT	00
CHROMA	00
PHASE	00

Table 3

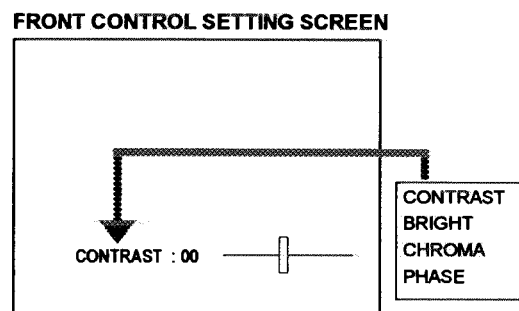

Fig.5

SERVICE MENU SETTING ITEMS

BLOCK	SERVICE NUMBER	CONTENTS		
1. SIGNAL BLOCK	S01	BRIGHT		
	S02	CONTRAST		
	S03	PAL	CHROMA	
	S04	NTSC	CHROMA	
	S05	SECAM	CHROMA	
	S06	NTSC	PHASE	
2. WHITE BALANCE BLOCK	W01	CUTOFF	R	
	W02		G	
	W03		B	
	W04	DRIVE	R	
	W05		B	
3. DEFLECTION BLOCK	D01	50Hz	HORIZONTAL CENTER	
	D02		VERTICAL SIZE	
	D03		V-S. CORRECTION	
	D04		VERTICAL CENTER(Not use)	
	D05		VERTICAL LINEARITY	
	DA1	60Hz	HORIZONTAL CENTER	
	DA2		VERTICAL SIZE	
	DA3		V-S. CORRECTION	
	DA4		VERTICAL CENTER (Not use)	
	DA5		VERTICAL LINEARITY	
4. CONTROL BLOCK	C01	MODEL		
	C02	BRIGHT POINT	UPPER	
	C03		LOWER	
	C04	CONTRAST POINT	UPPER	
	C05		LOWER	
	C06	CHROMA POINT	UPPER	
	C07		LOWER	
	C08	PHASE POINT	UPPER	
	C09		LOWER	
		C10	OSD H POSITION	
		C11	OSD V POSITION 50Hz	
		C12	OSD V POSITION 60Hz	
		C13	Y DELAY NTSC VIDEO	
		C14	Y DELAY PAL VIDEO	
		C15	Y DELAY SECAM VIDEO	
		C16	Y DELAY BW VIDEO	
		C17	Y DELAY NTSC S VIDEO	
		C18	Y DELAY PAL S VIDEO	
		C19	Y DELAY SECAM S VIDEO	
		C20	Y DELAY BW S VIDEO	
		C21	BRIGHT SERVICE	
		C22	SHARPNESS CENTER	
		C23	VERTICAL GUARD	
		C24	HOUR METER	
		C25	AFC MODE	
		C26	BURST POSITION NTSC/PAL	
		C27	BURST POSITION SECAM	
		C28	COLOUR SYSTEM	
		C29	REMOCON	
		C30	S-FILED	

BLOCK	SERVICE NUMBER	CONTENTS
4. CONTROL BLOCK	C31	SCD. ATT
	C32	DEMP. F0
	C33	V. ID. SW
	C34	S. KILL
	C35	BELL. F0
	C36	ABL GAIN
	C37	ABL POINT
	C38	C-TRAP SW NTSC
	C39	C-TRAP SW PAL
	C40	C-TRAP Q NTSC
	C41	C-TRAP Q PAL
	C42	C-TRAP F0 NTSC
	C43	C-TRAP F0 PAL
	C44	C-TOF SW NTSC
	C45	C-TOF SW PAL
	C46	C-TOF Q NTSC
	C47	C-TOF Q PAL
	C48	C-TOF F0 NTSC
	C49	C-TOF F0 PAL
	C50	SHARPNESS F0 NTSC VIDEO
C51	SHARPNESS F0 PAL VIDEO	
C52	SHARPNESS F0 SECAM VIDEO	
C53	SHARPNESS F0 S VIDEO	

SERVICE ADJUSTMENTS

BEFORE STARTING SERVICE ADJUSTMENT

1. Supply power to the set and measuring instruments and allow to warm up for at least 30 minutes.
2. Confirm the proper AC power voltage is being supplied.
3. The setting is made on basis of the initial setting values. The setting values which adjust the screen to the optimum condition can be different from the initial setting values.
4. Use care not to disturb controls and switches not mentioned in the adjustment items.
5. Refer to adjustment settings and set user operated controls (BRIGHT, CONTRAST, PHASE, CHROMA, etc.) to the indicated positions.

MEASUREING INSTRUMENTS AND FIXTURES

- DC voltmeter (digital voltmeter)
 - Oscilloscope
 - Signal generator (PAL/NTSC systems)
 - Colour bar and split color bar patterns
 - Crosshatch pattern
 - Cross pattern
 - Red raster pattern
 - Green raster pattern
 - Blue raster pattern
 - Philips pattern (including R-Y and B-Y)
 - TV resolution pattern
 - Colour analyzer
 - High voltage meter
- The wave form of signals refer following figure.

VIDEO SIGNAL

● COLOUR BAR (PAL / NTSC) SIGNAL

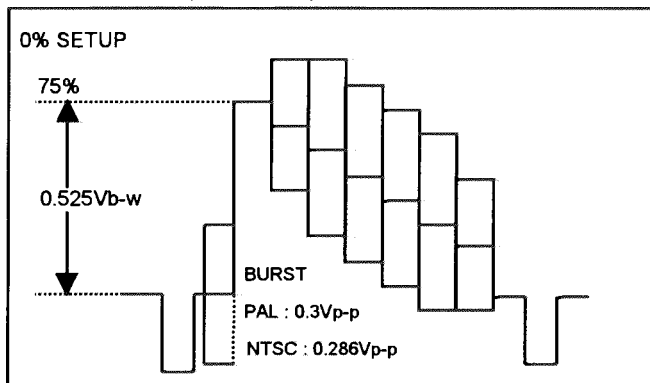

Y/C SEPARATE SIGNAL

● COLOUR BAR SIGNAL

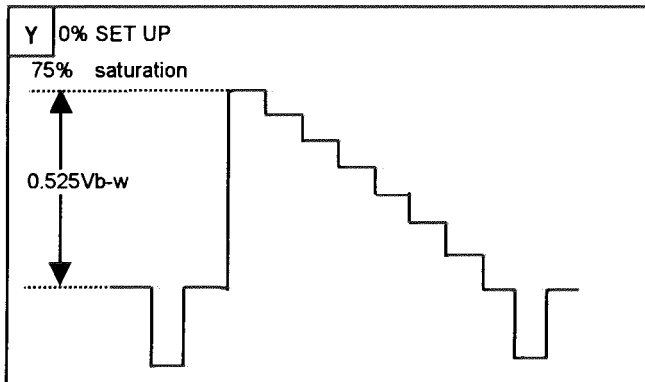

● COLOUR BAR SIGNAL

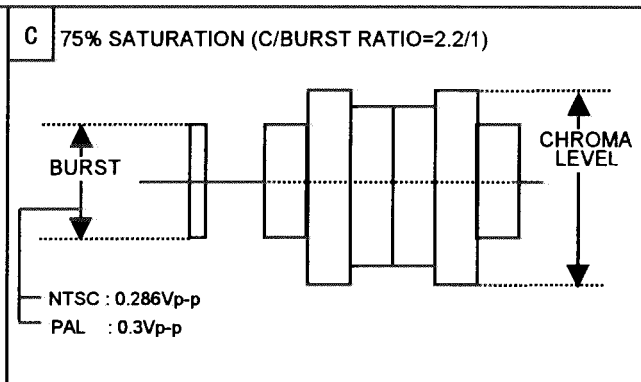

ADJUSTMENT SETTINGS

1. Front controls

PHASE00 (NTSC only)
CHROMA00
BRIGHT00
CONTRAST00
VOLUME20

2. Front switches

INPUT SELECT.....VIDEO A

3. MENU screen

SHARPNESS.....00
COLOUR SYSTEM.....AUTO

ADJUSTMENT LOCATIONS

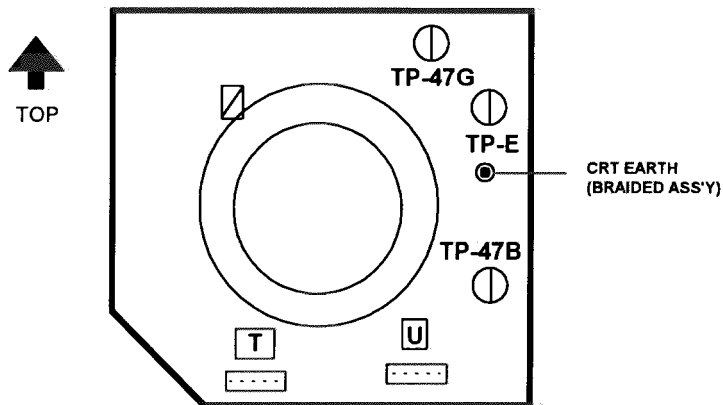
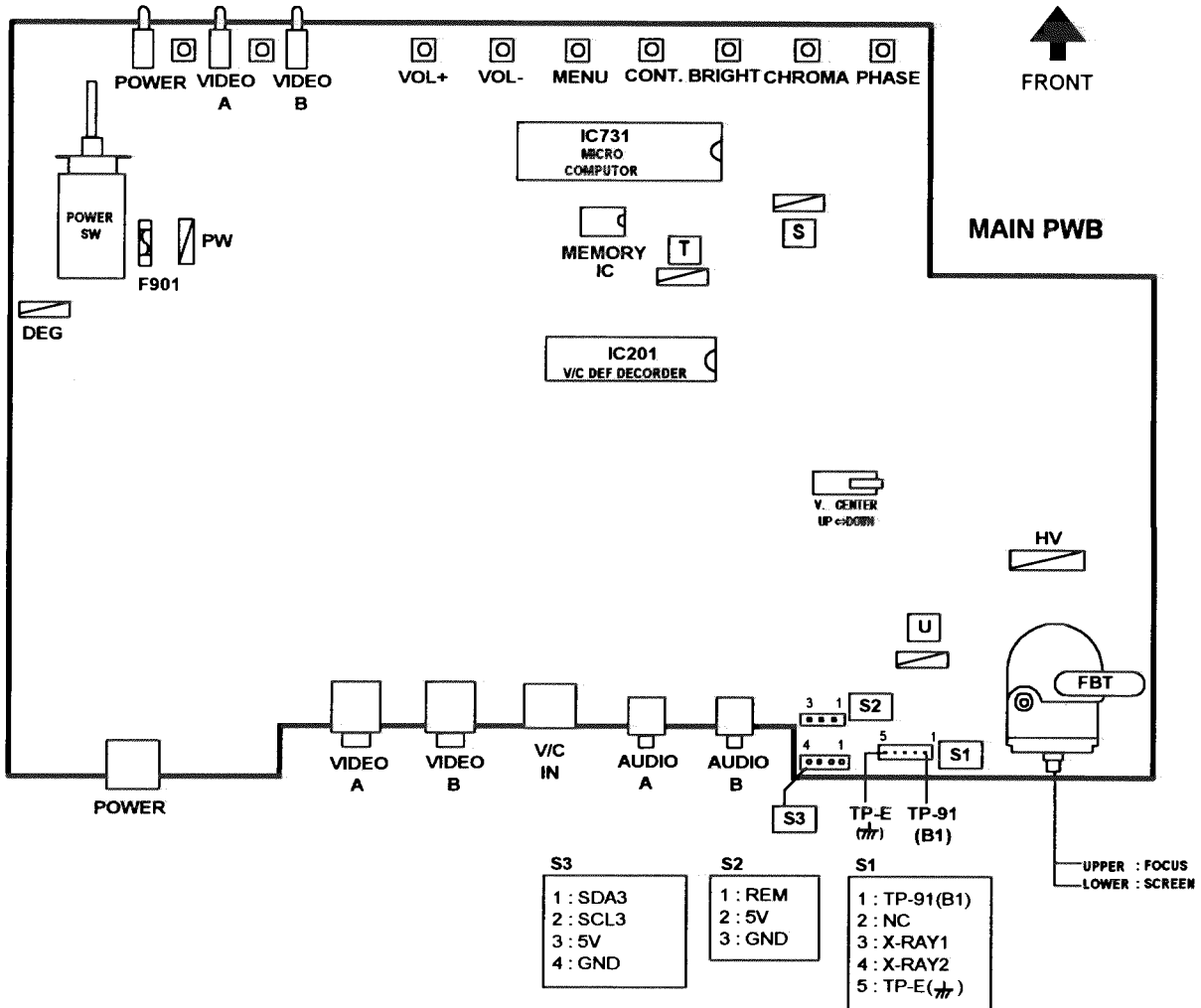

CRT SOCKET PWB (SOLDER SIDE)
(Within MAIN PWB)

BASIC OPERATION OF THE SERVICE MENU

1. SERVICE MENU ITEMS

With the SERVICE MENU, various settings can be made, and they are broadly classified in the following items of adjustments.

Don't change the values, if not to necessary.

SIGNAL BLOCK This mode adjusts the data of the various signal voltage controls.

WHITE BALANCE BLOCK This mode adjusts the data of the WHITE BALANCE adjustment.

DEFLECTION BLOCK This mode adjusts the data of the DEFLECTION circuit.

CONTROL BLOCK This mode adjusts the whole of the systems

2. BASIC OPERATION OF THE SERVICE MENU

(1) HOW TO ENTER THE SERVICE MAIN MENU

- ① Press **MENU** key and **CONTRAST** key simultaneously.
- ② The letter "S" appears at the upper left of the screen.(Fig.1)
- ③ While "S" is displayed, press **MENU** key and **PHASE** key simultaneously.
- ④ The screen display "PLEASE DON'T TOUCH".(Fig.2)
- ⑤ While "PLEASE DON'T TOUCH" is displayed, press + key or - key to display the SERVICE MAIN MENU as shown in Fig.3.

NOTE

If step ④ state continues for more than 5 seconds without a further operation, the display extinguishes and the mode is released.

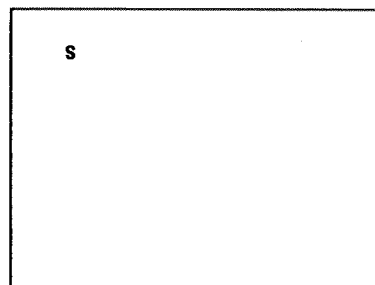

Fig.1

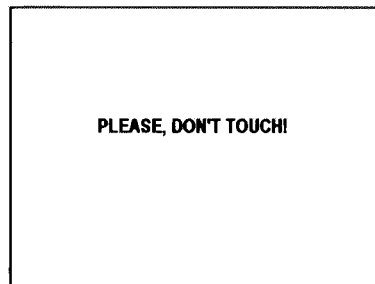

Fig.2

(2) SELECT OF SUB MENU SCREEN

- While the SERVICE MAIN MENU is displayed.
In accordance with the key control display at the lower side of the screen, operate the various items.

SIGNAL BLOCK Press the **PHASE** key
WHITE BALANCE BLOCK Press the **CHROMA** key
DEFLECTION BLOCK..... Press the **BRIGHT** key
CONTROL BLOCK..... Press the **CONTRAST** key

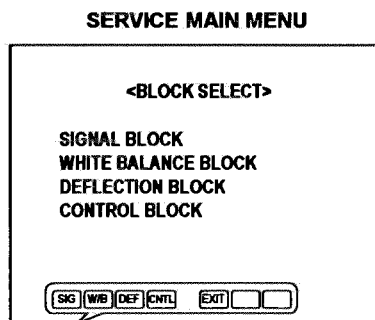

Fig.3

(3) SETTING VALUE CHANGES

- While the adjustment mode menu is displayed.(Fig.4)
- ① Press the +key or -key to change the setting value.
 - ② Press the **PHASE** or **CHROMA** key to change the adjustment items.

(4) SERVICE MENU EXIT

- ① When settings are completed, press **MENU** key.
- ② The SERVICE MAIN MENU returns.
- ③ Again press **MENU** key.
- ④ The screen display extinguishes and the SERVICE MENU is exited.

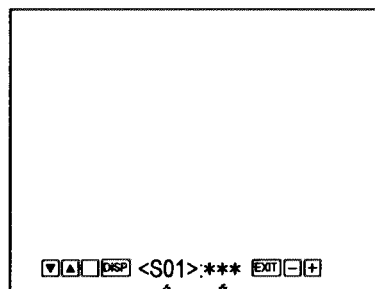
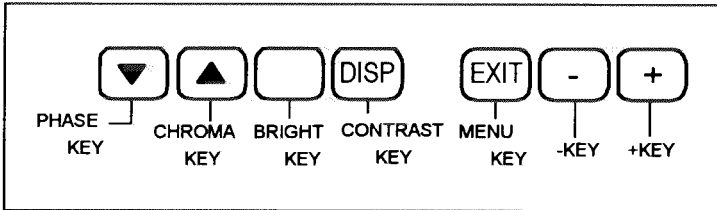

Fig.4
Value Adjustment item

3. HOW TO OPERATE SERVICE MENU ITEMS

■ SIGNAL BLOCK

- ① Press the **PHASE** key from the <BLOCK SELECT> screen (SERVICE MAIN MENU).
- ② Then displays the SIGNAL BLOCK adjustment screen (Fig.5)
- ③ The select item is shown by the SERVICE Number at the lower of the screen.
- ④ Key control operation are displays as same as the screen lower. The key operations of this mode are following as shown below.



NOTE

CONTRAST key is the switch of the screen display. If necessary, you can shut off the display. Carefully, values of SERVICE MENU adjustment items are changed while shut off the screen display.

- ⑤ Press the **MENU** key, then exit from the SIGNAL BLOCK screen to return to the <BLOCK SELECT> screen.

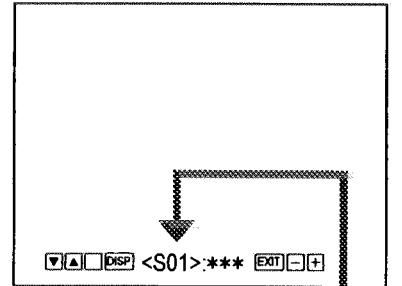

Fig.5

SERVICE Number

■ WHITE BALANCE BLOCK

- ① Press the **CHROMA** key from the <BLOCK SELECT> screen (SERVICE MAIN MENU).
- ② Then screen displays the WHITE BALANCE BLOCK adjustment screen (Fig.6)

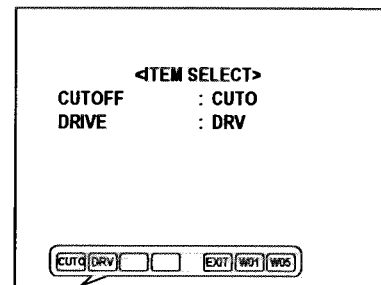
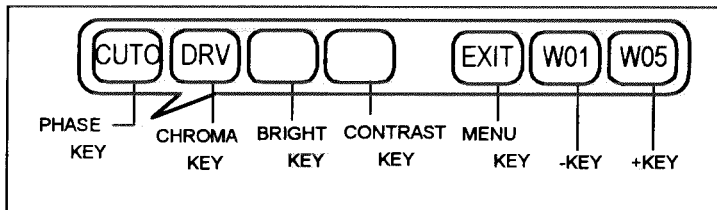

Fig.6

- ③ The select item is shown by the SERVICE Number at the lower of the screen.
- ④ Press the **MENU** key few times, then exit from the WHITE BALANCE BLOCK screen to return to the <BLOCK SELECT> screen.

[WHITE BALANCE Adjustment : METHOD 1]

Accordance with the screen, select the WHITE BALANCE mode that following below.

• **CUTOFF adjustment mode (LOW LIGHT)**

Press the **PHASE** key, then enter the CUTOFF adjustment mode as shown in Fig.7 (LOW LIGHT adjustment mode). In this case, key control is changed as shown below.

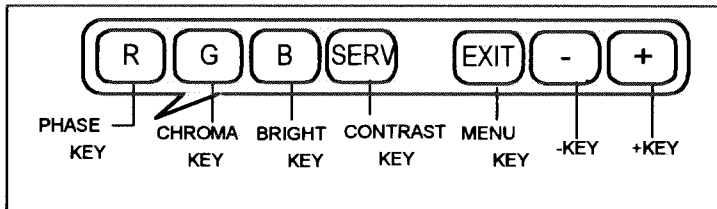

Press key of the SERV displaying. Shown **ONE HORIZONTAL LINE** on or off.

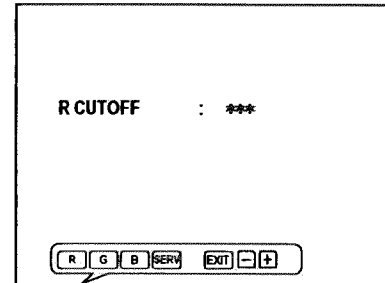

Fig.7

• **DRIVE adjustment mode (HIGH LIGHT)**

Press the **CHROMA** key, then enter the DRIVE adjustment mode as shown in Fig.8 (HIGH LIGHT adjustment mode). In this case, key control is changed as shown below.

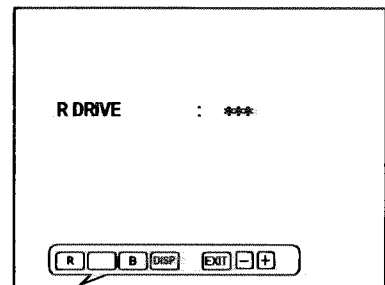
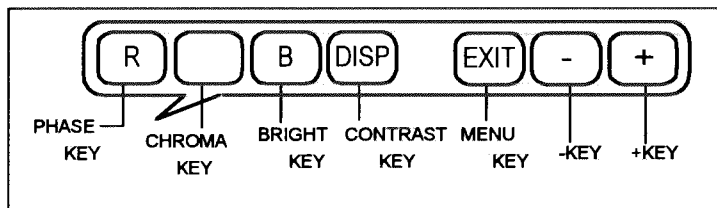

Fig.8

[WHITE BALANCE Adjustment : METHOD 2]

Accordance with the screen, select the WHITE BALANCE mode that following below.

Press the +key or -key, then enter the WHITE BALANCE full adjustment mode as shown in Fig.9 (this mode both LOW LIGHT and HIGH LIGHT are able to adjust). In this case, key control is changed as shown below. The operation of this mode is as same as SIGNAL BLOCK adjustment operation.

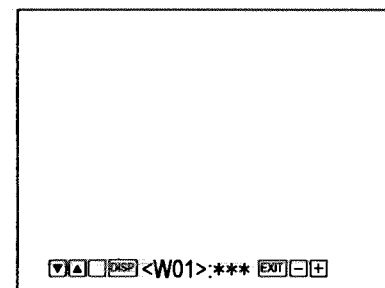
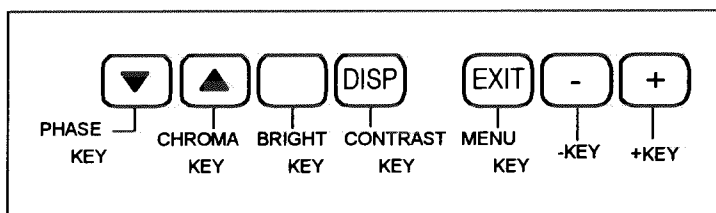

Fig.9

■ DEFLECTION BLOCK

- ① Press the **BRIGHT** key from the <BLOCK SELECT> screen (SERVICE MAIN MENU).
- ② Then screen displays the DEFLECTION BLOCK adjustment screen (Fig.10).
- ③ The select item is shown by the SERVICE Number at the lower of the screen.
- ④ The adjustment screen changes by case of the signal that use for adjustment (Vertical frequency).

SIGNAL	SCREEN DISPLAY
50Hz	<D0?>
60Hz	<DA?>

Key control operation are displays as same as the screen lower. The key operations of this mode are following as shown below.

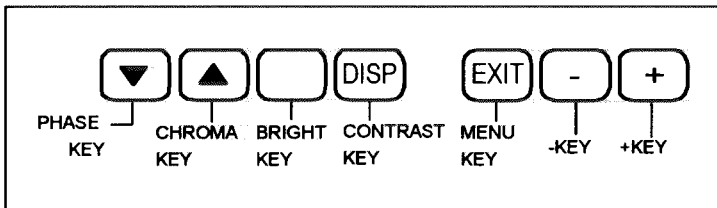

NOTE

CONTRAST key is the switch of the screen display. If necessary, you can shut off the display. Carefully, values of SERVICE MENU adjustment items are changed while shut off the screen display.

■ CONTROL BLOCK (Don't change the values, if not to necessary).

- ① Press the **CONTRAST** key from the <BLOCK SELECT> screen (SERVICE MAIN MENU).
- ② Then screen displays the CONTROL BLOCK adjustment screen (Fig.11)
- ③ The select item is shown by the SERVICE Number at the lower of the screen.
- ④ Key control operation are displays as same as the screen lower. The key operations of this mode are following as shown below.

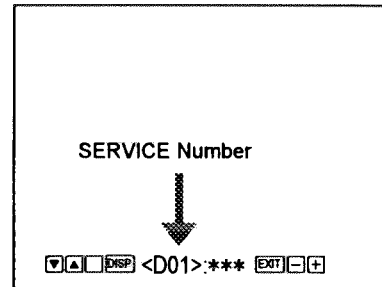
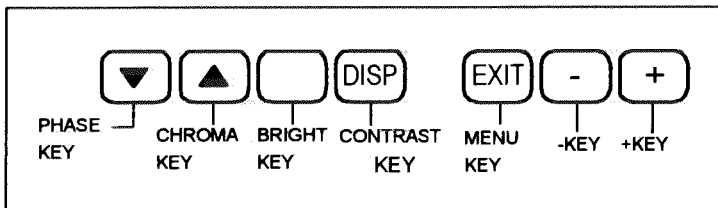

Fig.10

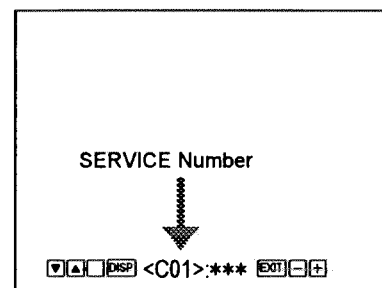
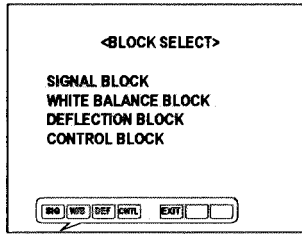

Fig.11

[SERVICE MAIN MENU]



[SUB MENU]

SIGNAL BLOCK

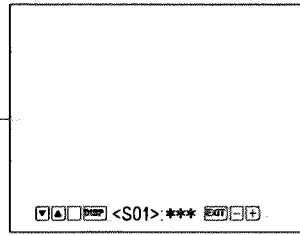

- S01 BRIGHT
- S02 CONTRAST
- S03 PAL CHROMA
- S04 NTSC CHROMA
- S05 SECAM CHROMA
- S06 NTSC PHASE

WHITE BALANCE BLOCK

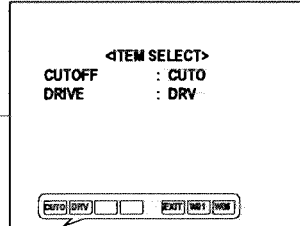

CUTOFF

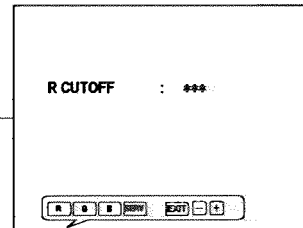

- R CUTOFF
- G CUTOFF
- B CUTOFF

DRIVE

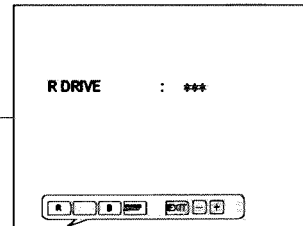

- R DRIVE
- B DRIVE

SERVICE NUMBER

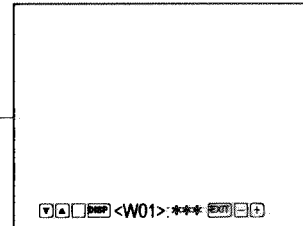

- W01 } R
- W02 } CUTOFF G
- W03 } B
- W04 } DRIVE R
- W05 } B

DEFLECTION BLOCK

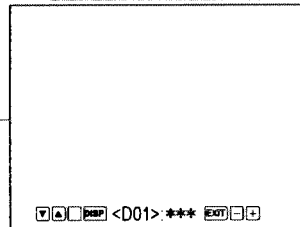

- D01(DA1) H. CENT
- D02(DA2) V. SIZE
- D03(DA3) V. S. CORRECTION
- D04(DA4) V. CENTER (Not use)
- D05(DA5) V. LINEARITY

CONTROL BLOCK

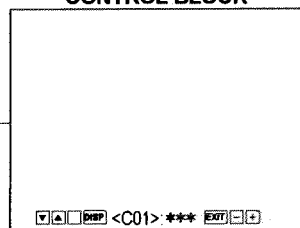

- | | | | |
|--------------|-----------------|-----------------|-------------------|
| C01 MODEL | C15 Y.D SECAM | C29 REMOCON | C43 C-TRAP F0 P |
| C02 BRIGHT | C16 Y.D BAW | C30 S-FILED | C44 C-TOF SW N |
| C03 | C17 Y.D NTSC S | C31 SCD.ATT | C45 C-TOF SW P |
| C04 CONTRAST | C18 Y.D PAL S | C32 DEMP.F0 | C46 C-TOF Q N |
| C05 | C19 Y.D SECAM S | C33 V.ID.SW | C47 C-TOF Q P |
| C06 CHROMA | C20 Y.D BAW S | C34 S.KILL | C48 C-TOF F0 N |
| C07 | C21 BRIGHT SER. | C35 BELL.F0 | C49 C-TOF F0 P |
| C08 PHASE | C22 SHARPNESS | C36 ABL GAIN | C50 SHARP. F0 N |
| C09 | C23 V.GUARD | C37 ABL POINT | C51 SHARP. F0 P |
| C10 OSD POS | C24 HOUR | C38 C-TRAP SW N | C52 SHARP. F0 SEC |
| C11 OSD V 50 | C25 AFC MODE | C39 C-TRAP SW P | C53 SHARP. F0 S |
| C12 OSD V 60 | C26 B.P.N/P | C40 C-TRAP Q N | |
| C13 Y.D NTSC | C27 B.P.SECAM | C41 C-TRAP Q P | |
| C14 Y.D PAL | C28 COL. SYS. | C42 C-TRAP F0 N | |

■ INITIAL SETTINGS OF THE SERVICE MENU ADJUSTMENT ITEMS

SIGNAL BLOCK

SERVICE Number	ITEMS	VARIABLE RANGE	INITIAL VALUE	DESCRIPTION
S01	BRIGHT	000 ~ 255	150	Avariable
S02	CONTRAST	000 ~ 255	070	
S03	CHROMA	PAL	000 ~ 255	
S04		NTSC	000 ~ 255	
S05		SECAM	000 ~ 255	
S06	PHASE	000 ~ 127	065	

WHITE BALANCE BLOCK

SERVICE Number	ITEMS	VARIABLE RANGE	INITIAL VALUE	DESCRIPTION
W01	CUTOFF	R	000 ~ 255	Avariable
W02		G	000 ~ 255	
W03		B	000 ~ 255	
W04	DRIVE	R	000 ~ 255	
W05		B	000 ~ 255	

DEFLECTION BLOCK

SERVICE Number	ITEMS	VARIABLE RANGE	INITIAL VALUE	DESCRIPTION
D01	50Hz	HORIZONTAL CENTER	000 ~ 031	Avariable
D02		VERTICAL	000 ~ 127	
D03		V-S. CORRECTION	000 ~ 063	
D04		VERTICAL CENTER	000 ~ 255	Don't touch
D05		VERTICAL LINEARITY	000 ~ 031	Avariable
DA1	60Hz	HORIZONTAL CENTER	-128 ~ 000 ~ +127	Avariable
DA2		VERTICAL	-128 ~ 000 ~ +127	
DA3		V-S. CORRECTION	-128 ~ 000 ~ +127	
DA4		VERTICAL CENTER	-128 ~ 000 ~ +127	Don't touch
DA5		VERTICAL LINEARITY	-128 ~ 000 ~ +127	Avariable

CONTROL BLOCK

SERVICE Number	ITEMS	VARIABLE RANGE	INITIAL VALUE	DESCRIPTION	
C01	MODEL	000 ~ 011	006	Reserve (Don't touch)	
C02	BRIGHT POINT	UPPER	000 ~ 255		063
C03		LOWER	000 ~ 255		063
C04	CONTRAST POINT	UPPER	000 ~ 255		063
C05		LOWER	000 ~ 255		063
C06	CHROMA POINT	UPPER	000 ~ 255		000
C07		LOWER	000 ~ 255		030
C08	PHASE POINT	UPPER	000 ~ 127		050
C09		LOWER	000 ~ 127		050
C10	OSD HORIZONTAL POSITION	000 ~ 015	012		
C11	OSD VERTICAL POSITION 50Hz	000 ~ 007	005		
C12	OSD VERTICAL POSITION 60Hz	000 ~ 002	000		
C13	Y DELAY NTSC VIDEO	000 ~ 007	000		
C14	Y DELAY PAL VIDEO	000 ~ 007	001		
C15	Y DELAY SECAM VIDEO	000 ~ 007	004		
C16	Y DELAY B/W VIDEO	000 ~ 007	001		
C17	Y DELAY NTSC S VIDEO	000 ~ 007	001		
C18	Y DELAY PAL S VIDEO	000 ~ 007	001		
C19	Y DELAY SECAM S VIDEO	000 ~ 007	001		
C20	Y DELAY B/W S VIDEO	000 ~ 007	001		
C21	BRIGHT SERVICE	000 ~ 255	150		
C22	SHARPNESS CENTER	000 ~ 063	017		
C23	VERTICAL GUARD	000 ~ 001	001		
C24	HOUR METER	000 ~ 650	001		
C25	AFC MODE	000 ~ 003	000		
C26	BURST POSITION NTSC/PAL	000 ~ 001	000		
C27	BURST POSITION SECAM	000 ~ 001	000		
C28	COLOUR SYSTEM SECAM	000 ~ 001	000		
C29	REMOCON	000 ~ 001	000		
C30	S-FILED	000 ~ 001	001		
C31	SCD. ATT	000 ~ 001	000		
C32	DEMP. F0	000 ~ 001	000		
C33	V. ID. SW	000 ~ 001	000		
C34	S. KILL	000 ~ 001	000		
C35	BELL. F0	000 ~ 001	000		
C36	ABL GAIN	000 ~ 007	004		
C37	ABL POINT	000 ~ 007	006		
C38	C-TRAP SW NTSC	000 ~ 001	000		
C39	C-TRAP SW PAL	000 ~ 001	000		
C40	C-TRAP Q NTSC	000 ~ 003	001		

SERVICE Number	ITEMS	VARIABLE RANGE	INITIAL VALUE	DESCRIPTION
C41	C-TRAP Q PAL	000 ~ 003	001	Reserve (Don't touch)
C42	C-TRAP F0 NTSC	000 ~ 003	002	
C43	C-TRAP F0 PAL	000 ~ 003	002	
C44	C-TOF NTSC	000 ~ 001	000	
C45	C-TOF PAL	000 ~ 001	000	
C46	C-TOF Q NTSC	000 ~ 003	000	
C47	C-TOF Q PAL	000 ~ 003	000	
C48	C-TOF F0 NTSC	000 ~ 003	000	
C49	C-TOF F0 PAL	000 ~ 003	000	
C50	SHARPNESS F0 NTSC VIDEO	000 ~ 003	000	
C51	SHARPNESS F0 PAL VIDEO	000 ~ 003	000	
C52	SHARPNESS F0 SECAM VIDEO	000 ~ 003	000	
C53	SHARPNESS F0 S VIDEO	000 ~ 003	000	

■ ADJUSTMENT

Item	Test equipment	Test points	Adjustment locations	Adjustment procedure
Check of B1 power supply	Voltmeter	TP-91(B1): S1 ① pin TP-E(↓): S1 ⑤ pin [MAIN PWB] SCREEN VR [In FBT]		<ol style="list-style-type: none"> 1. Set power supply voltage to 230V. 2. Select WHITE BALANCE BLOCK from the SERVICE MAIN MENU. 3. Select CUTOFF adjustment mode (LOW LIGHT mode). 4. Press "SERV" switch as CONTRAST key, to display the horizontal line. 5. Adjust the SCREEN VR to disappear the horizontal line. 6. Check the B1 voltage to 114.0V ± 2V. 7. Readjust the SCREEN VR to appear the horizontal line faintly, and cancel the horizontal line to press the "SERV" switch.
High voltage check	High voltage meter Signal generator (All-black signal)	CRT Anode SCREEN VR [In FBT]		<ol style="list-style-type: none"> 1. Set power supply voltage to 230V. 2. Select WHITE BALANCE BLOCK from the SERVICE MAIN MENU. 3. Select CUTOFF adjustment mode (LOW LIGHT mode). 4. Press "SERV" switch as CONTRAST key, to display the horizontal line. 5. Adjust the SCREEN VR to disappear the horizontal line. 6. Connect the high voltage meter to the CRT anode and check for 24.0~26.0kV. 7. Readjust the SCREEN VR to appear the horizontal line faintly, and cancel the horizontal line to press the "SERV" switch.
Focus adjustment	Signal generator (Cross-hatch pattern)		FOCUS VR [In FBT]	<ol style="list-style-type: none"> 1. Adjust the Focus VR for optimum focus where moire is not apparent. 2. Darken the picture and adjust the focus by tuning counter-clockwise from the position where focus is poor. 3. Alternately repeat the above steps to obtain the optimum position. <ul style="list-style-type: none"> • Focus can be adjusted easily by displaying the menu.

Item	Test equipment	Test points	Adjustment locations	Adjustment procedure
White balance (Low Light) adjustment	Signal generator (Resolution pattern, Colour bar Pattern)		SCREEN VR [In FBT] W01 (R CUTOFF) W02 (G CUTOFF) W03 (B CUTOFF) [SERVICE MENU]	<ol style="list-style-type: none"> 1. Supply the resolution pattern. 2. Select the WHITE BALANCE BLOCK from the SERVICE MAIN MENU. 3. Select the CUTOFF mode. 4. Confirm the values of the R.G.B CUTOFF are the 50. 5. Press "SERV" switch as CONTRAST key, to display the horizontal line. Carefully adjust the SCREEN VR to horizontal line appears faintly, not to shine it much. 6. Gradually turn the SCREEN VR clockwise to bring one of the red, green and blue colours faintly visible. 7. Then select the CUTOFF switch (R, G or B) that colour except for appears first, and adjusting 2 colours CUTOFF values by pressing the +key, and make horizontal line visible white. 8. Readjust the SCREEN VR to appear the horizontal line faintly, and cancel the horizontal line to press the "SERV" switch.
White balance (Hight Light) adjustment	Signal generator (Resolution pattern) Colour Analyzer or Colour temperature meter		W04 (R DRIVE) W05 (B DRIVE) [SERVICE MENU]	<ol style="list-style-type: none"> 1. Supply the resolution pattern. 2. Select the WHITE BALANCE BLOCK from the SERVICE MAIN MENU. 3. Select the DRIVE mode. 4. Apply the sensor of the Colour temperature meter to the CRT surface, part of the 100% white, adjust the R drive or B drive to setting 6500K (x=0.313, y=0.329). 5. Exit the SERVICE MENU by pressing the MENU key. 6. Check the white balance tracking is optimum when CONTRAST and BRIGHT are up and down.

Item	Test equipment	Test points	Adjustment locations	Adjustment procedure
Bright adjustment	Signal generator (Sprit colour bar)		S01 (BRIGHT) [SERVICE MENU]	<ol style="list-style-type: none"> 1. Supply a sprit colour bar signal. 2. Select the SIGNAL BLOCK from the SERVICE MAIN MENU. 3. Select the <S01> item. 4. Adjust <S01> to where the sprit colour bar 0% black component faintly brightens. 5. Check it to on and off the screen display by turning the "DISP" switch.
Contrast adjustment	Signal generator (Cross-hatch) Oscillo-scope	TP-47G TP-E(↘) [CRT SOCKET PWB]	S02 (CONTRAST) [SERVICE MENU]	<ol style="list-style-type: none"> 1. Supply a cross-hatch signal. (level 75%) 2. Connect the oscillo-scope probe to TP-47G and TP-E(↘). 3. Select the SIGNAL BLOCK from SERVICE MAIN MENU. 4. Select the <S02> item. 5. Adjust <S02> to set the waveform level to $(37 \pm 2)V_{p-p}$ as shown in figure.

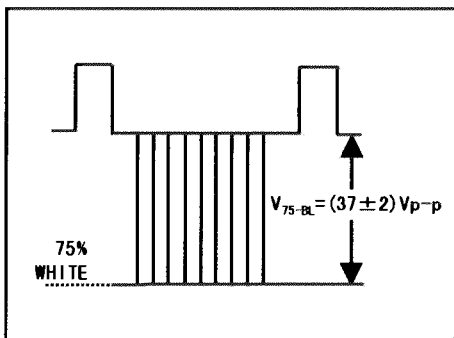

Item	Test equipment	Test points	Adjustment locations	Adjustment procedure
PAL CHROMA adjustment	Signal generator (Colour bar) Oscillo-scope	TP-47B TP-E(↕) [CRT SOCKET PWB]	S03 (PAL CHROMA) [SERVICE MENU]	<ol style="list-style-type: none"> 1. Supply a PAL colour bar signal. 2. Connect the oscillo-scope probe to TP-47B and TP-E(↕). 3. Select the SIGNAL BLOCK from SERVICE MAIN MENU. 4. Select the <S03> item. 5. Adjust the <S03> to take the level difference in waveform is $0V \pm 2V$ as shown in figure.
NTSC CHROMA adjustment	Signal generator (Colour bar) Oscillo-scope	TP-47B TP-E(↕) [CRT SOCKET PWB]	S04 (NTSC CHROMA) [SERVICE MENU]	<ol style="list-style-type: none"> 1. Supply a NTSC 3.58 colour bar signal. 2. Connect the oscillo-scope probe to TP-47B and TP-E(↕). 3. Select the SIGNAL BLOCK from SERVICE MAIN MENU. 4. Select the <S04> item. 5. Adjust the <S04> to take the level difference in waveform is $0V \pm 2V$ as shown in figure.
NTSC PHASE adjustment	Signal generator (Colour bar) Oscillo-scope	TP-47B TP-E(↕) [CRT SOCKET PWB]	S06 (NTSC PHASE) [SERVICE MENU]	<ol style="list-style-type: none"> 1. Supply a NTSC 3.58 colour bar signal. 2. Connect the oscillo-scope probe to TP-47B and TP-E(↕). 3. Select the SIGNAL BLOCK from SERVICE MAIN MENU. 4. Select the <S06> item. 5. Adjust the <S06> to take the level difference in waveform is $0V \pm 2V$ as shown in figure.

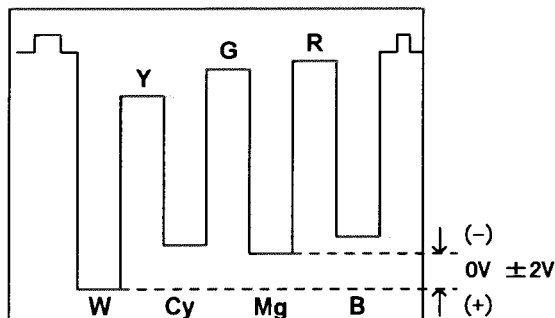
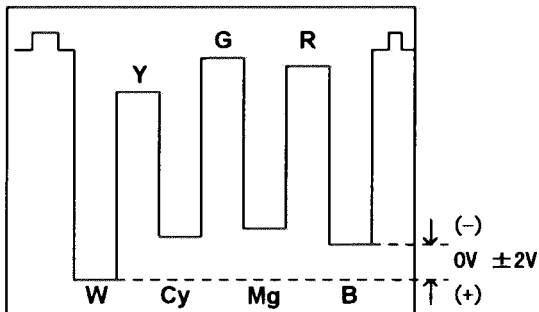
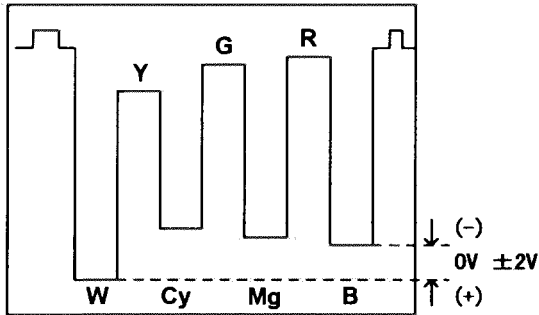

DEFLECTION CIRCUIT ADJUSTMENT

- There are 2 modes of DEFLECTION ADJUSTMENT — ① 50Hz and ② 60Hz — depending upon the kind of input signals (VERTICAL FREQUENCY 50Hz/60Hz).

- * When adjusted in the ① 50Hz mode, the ② 60Hz mode will be linked to the mode ① and will be automatically adjusted for the same value.
- * When adjusted in the ② 60Hz mode, only this mode will be adjusted singly.

NOTE

Adjustments for VERTICAL FREQUENCY shall always be carried out in regular order : ① 50Hz → ② 60Hz.

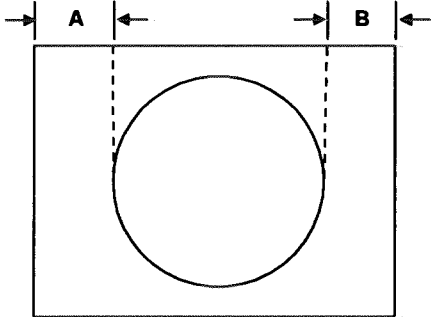
Item	Test equipment	Test points	Adjustment locations	Adjustment procedure
H.CENTER adjustment	Signal generator (Circle pattern)		D01 (H.CENTER) [SERVICE MENU]	<ol style="list-style-type: none"> 1. Supply a PAL (50Hz) circle pattern signal. 2. Select DEFLECTION BLOCK from SERVICE MAIN MENU. 3. Select <D01> item. 4. Adjust <D01> to align the picture center with the CRT center. (A=B)

Item	Test equipment	Test points	Adjustment locations	Adjustment procedure
V.SIZE adjustment	Signal generator (Cross-hatch pattern)		D02 (V.SIZE) [SERVICE MENU] V.CENTER SW [ON MAIN PWB]	5. Set the vertical center to go best position by selecting the V.CENTER SW. 6. Select <D02> item. 7. Adjust <D02> to set vertical size to 92%
V-S. CR V-LINE adjustment	Signal generator (Cross-hatch pattern)		D03 (V-S correction) D05 (V-LINEARITY)	8. Select <D03> and <D05> item. 9. Adjustment <D03> and <D05> to distance of each horizontal lines are equal. 10. If necessary, repeat above (5)~(9).
				Make sure that the adjustments is properly done on the screen of 60Hz. If screen of the deflection adjustment is not optimum in 60Hz mode, adjust the deflection setting.

SELF DIAGNOSIS FUNCTION

1. OUTLINE

This model includes a SELF DIAGNOSIS FUNCTION that checks the circuit operating status and in event of malfunction, displays and stores the data in a memory. The data are stored in an I²C memory.

Fault detection starts with the I²C bus and is performed according to the input states of the control lines connected to the MAIN CPU.

2. USAGE

SELF DIAGNOSIS FUNCTION mode entry

- (1) While press the MENU key and CHROMA key simultaneously, and push the MAIN POWER switch on.
- (2) Then displays the SELF DIAGNOSIS FUNCTION screen. The screen display as shown Fig.1 and the SELF DIAGNOSIS FUNCTION mode is entered. If in event a malfunction at RASTER not display, at this time POWER LED or POWER & VIDEO A LED flashes.

PROTECTOR		
B1	:	○
X-RAY	:	○
P-CHK	:	○
V.NECK	:	○
BUS		
MEMORY	:	○
TV-PRO	:	○

Fig.1

DISPLAY	CAUSE	LED FLASHING CYCLE	INDICATED LED
B1	OVER CURRENT PROTECTOR (B1)	1.0 sec on / 1.0 sec off cycles	POWER
X-RAY	X-RAY PROTECTOR	0.1 sec on / 0.1 sec off cycles	POWER
P-CHK	OVER CURRENT PROTECTOR (LOW B)	0.5 sec on / 0.5 sec off cycles	POWER
V.NECK	CRT-NECK PROTECTOR	1.0 sec on / 1.0 sec off cycles	POWER & VIDEO A

SELF DIAGNOSIS FUNCTION mode release

Turn the power switch to off or disconnect the power cord from AC outlet. In this way, not to clear the error counts.

Reset the error count

While entered in this mode, press the MENU key and “-” (DOWN) key simultaneously. Then clear the error count of the each item.

Fault history

The fault history counts up to a maximum of 9 times for each item. If the number of times exceeds 9, the display remains at 9. The fault history remains stored in the memory until deleted.

CONTENTS

CHECK ITEM	DISPLAY	DETECTION CONTENTS
POWER DEF CIRCUIT	B1	Over current protector operation and over voltage protector operation.
	X-RAY	
	P-CHK	
	V. NECK	V. OUT is abnormal
MEMORY IC AND DATA	MEMORY	Normal memory IC read / write operation
SINGLE CHIP TV PROCESSOR	TV-PRO	Normal IC101 (IF/DET/V/C/DEF) operation

TM-A14PN
TM-A14PN-K

TM-A14PN TM-A14PN-K STANDARD CIRCUIT DIAGRAM

■ NOTE ON USING CIRCUIT DIAGRAMS

1. SAFETY

The components identified by the Δ symbol and shading are critical for safety. For continued safety replace safety critical components only with manufactures recommended parts.

2. SPECIFIED VOLTAGE AND WAVEFORM VALUES

The voltage and waveform values have been measured under the following conditions.

- (1) Input signal :PAL Colour bar signal
- (2) Setting positions of each knob/button and variable resistor :Original setting position when shipped
- (3) Internal resistance of tester :DC 20k Ω /V
- (4) Oscilloscope sweeping time :H \Rightarrow 20 μ S/div
:V \Rightarrow 5mS/div
:Others \Rightarrow Sweeping time is specified
- (5) Voltage values :All DC voltage values

* Since the voltage values of signal circuit vary to some extent according to adjustments, use them as reference values.

3. INDICATION OF PARTS SYMBOL [EXAMPLE]

- In the PW board :R1209 \rightarrow R209

4. INDICATIONS ON THE CIRCUIT DIAGRAM

(1) Resistors

● Resistance value

- No unit :[Ω]
- K :[K Ω]
- M :[M Ω]

● Rated allowable power

- No indication :1/6[W]
- Others :As specified

● Type

- No indication :Carbon resistor
- OMR :Oxide metal film resistor
- MFR :Metal film resistor
- MPR :Metal plate resistor
- UNFR :Uninflammable resistor
- FR :Fusible resistor

*Composition resistor 1/2 [W] is specified as 1/2S or Comp.

(2) Capacitors

● Capacitance value

- 1 or higher :[pF]
- less than 1 :[μ F]

● Withstand voltage

- No indication :DC50[V]
- Others :DC withstand voltage [V]

*Electrolytic Capacitors

47/50[Example]:Capacitance value [μ F]/withstand voltage[V]

● Type

- No indication :Ceramic capacitor
- MY :Mylar capacitor
- MM :Metalized mylar capacitor
- PP :Polypropylene capacitor
- MPP :Metalized polypropylene capacitor
- MF :Metalized film capacitor
- TF :Thin film capacitor
- BP :Bipolar electrolytic capacitor
- TAN :Tantalum capacitor

(3) Coils



- No unit :[μ H]
- Others :As specified

(4) Power Supply



-  :B1
-  :B2(12V)
-  :9V
-  :5V

*Respective voltage values are indicated





(5) Test point

-  :Test point
-  :Only test point display

(6) Connecting method

-  :Connector
-  :Wrapping or soldering
-  :Receptacle

(7) Ground symbol

-  :LIVE side ground
-  :ISOLATED(NEUTRAL) side ground
-  :EARTH ground
-  :DIGITAL ground

5. NOTE FOR REPAIRING SERVICE

This model's power circuit is partly different in the GND. The difference of the GND is shown by the LIVE : (\perp) side GND and the ISOLATED(NEUTRAL) : (\perp) side GND. Therefore, care must be taken for the following points.

- (1) Do not touch the LIVE side GND or the LIVE side GND and the ISOLATED(NEUTRAL) side GND simultaneously. If the above caution is not respected, an electric shock may be caused. Therefore, make sure that the power cord is surely removed from the receptacle when, for example, the chassis is pulled out.
- (2) Do not short between the LIVE side GND and ISOLATED(NEUTRAL) side GND or never measure with a measuring apparatus (oscilloscope, etc.) the LIVE side GND and ISOLATED(NEUTRAL) side GND at the same time. If the above precaution is not respected , a fuse or any parts will be broken.

◇ Since the circuit diagram is a standard one, the circuit and circuit constants may be subject to change for improvement without any notice.

CONTENTS

SEMICONDUCTOR SHAPES..... 2-2

BLOCK DIAGRAM..... 2-3

CIRCUIT DIAGRAMS AND PATTERN DIAGRAMS..... 2-5

MAIN PWB CIRCUIT DIAGRAM (FX-1099A-U2)

MAIN PWB CIRCUIT DIAGRAM (Micro computer & Front control circuit)..... 2-5

MAIN PWB CIRCUIT DIAGRAM (Video processor, CRT & Audio circuit)..... 2-7

MAIN PWB CIRCUIT DIAGRAM (Power & Deflection circuit)..... 2-9

MAIN PWB PATTERN (FX-1099A-U2)..... 2-11

CRT SOCKET PWB PATTERN (Within Main PWB)..... 2-13

SEMICONDUCTOR SHAPES

TRANSISTOR

BOTTOM VIEW	FRONT VIEW				TOP VIEW
					CHIP TR

IC

BOTTOM VIEW	FRONT VIEW			TOP VIEW

CHIP IC

TOP VIEW		

BLOCK DIAGRAM

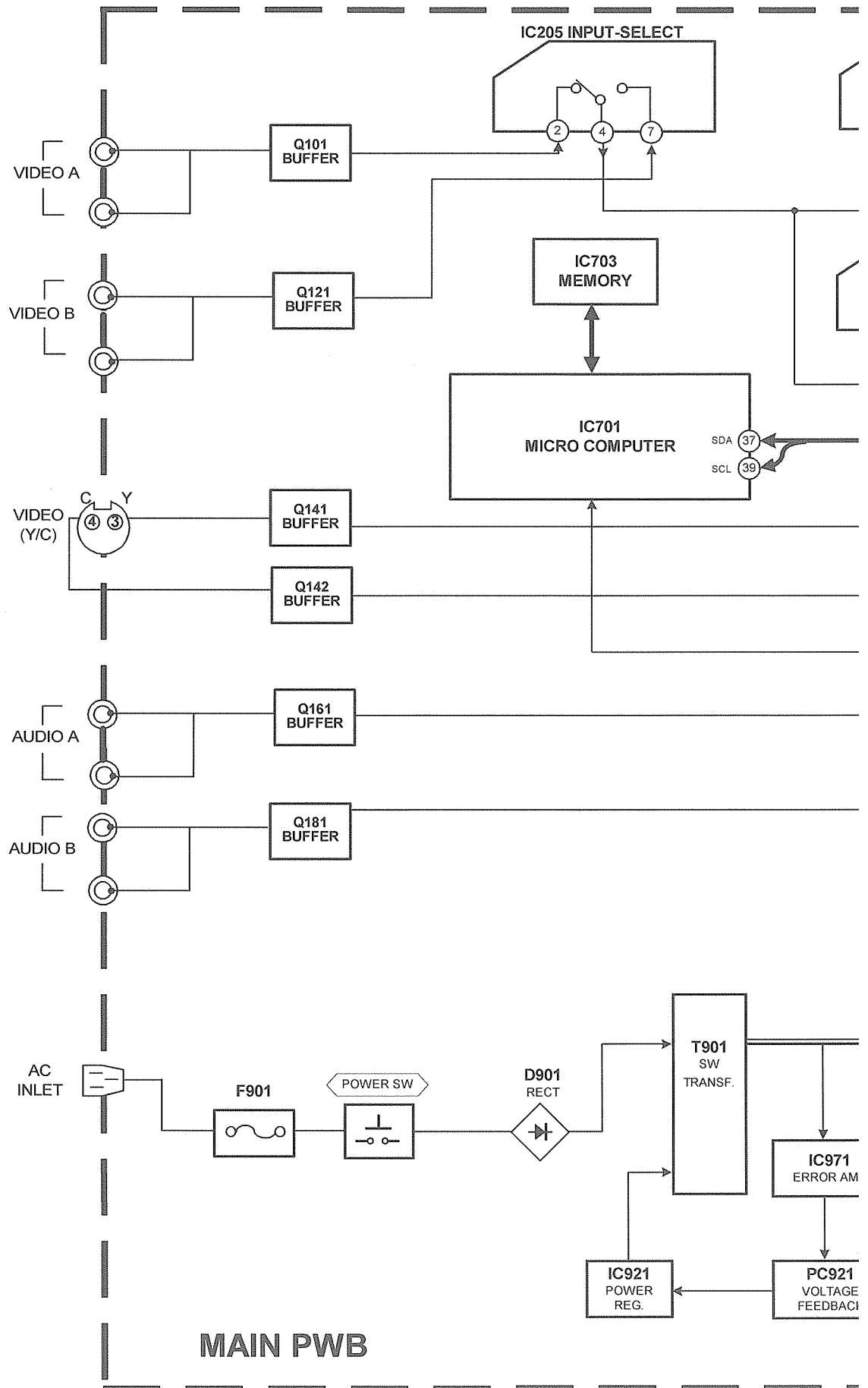

-A14PN
14PN-K

TM-A14PN
TM-A14PN-K

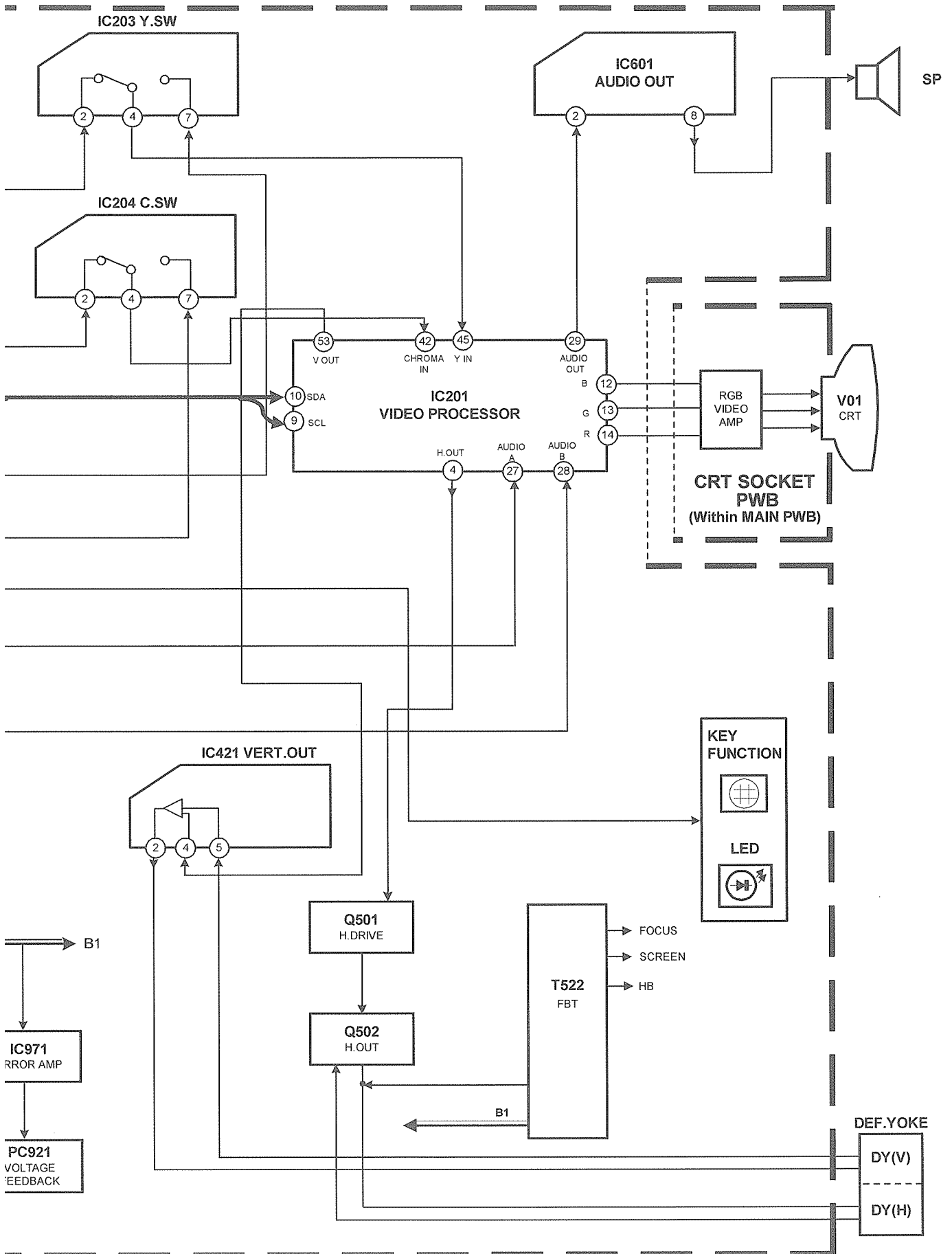

CIRCUIT DIAGRAMS

MAIN PWB CIRCUIT DIAGRAM [Micro computer & Front control]

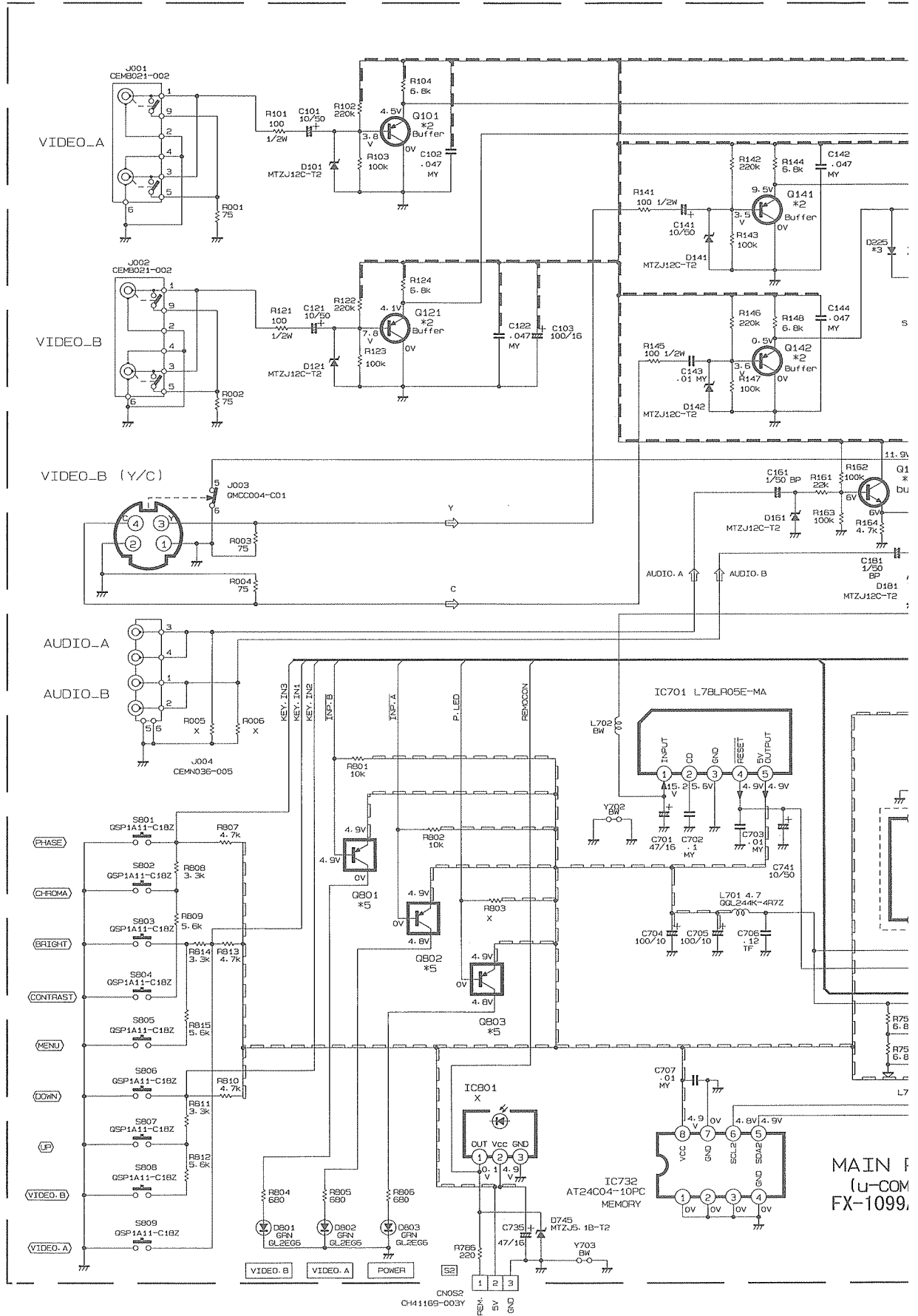

IC205 LA7016
INPUT_SELECT

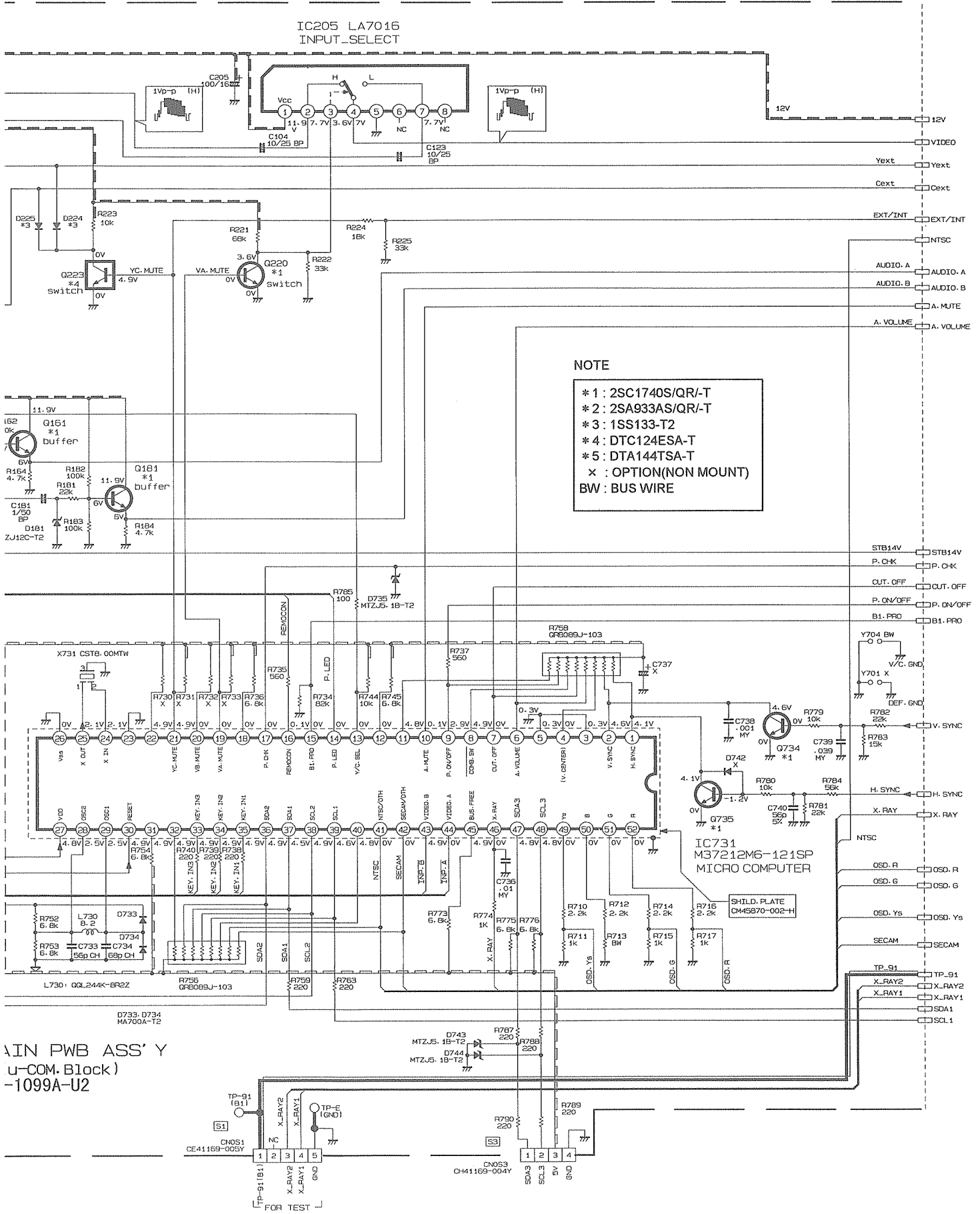

AIN PWB ASS'Y
u-COM. Block)
-1099A-U2

MAIN PWB CIRCUIT DIAGRAM [Video processor, CRT & Audio]

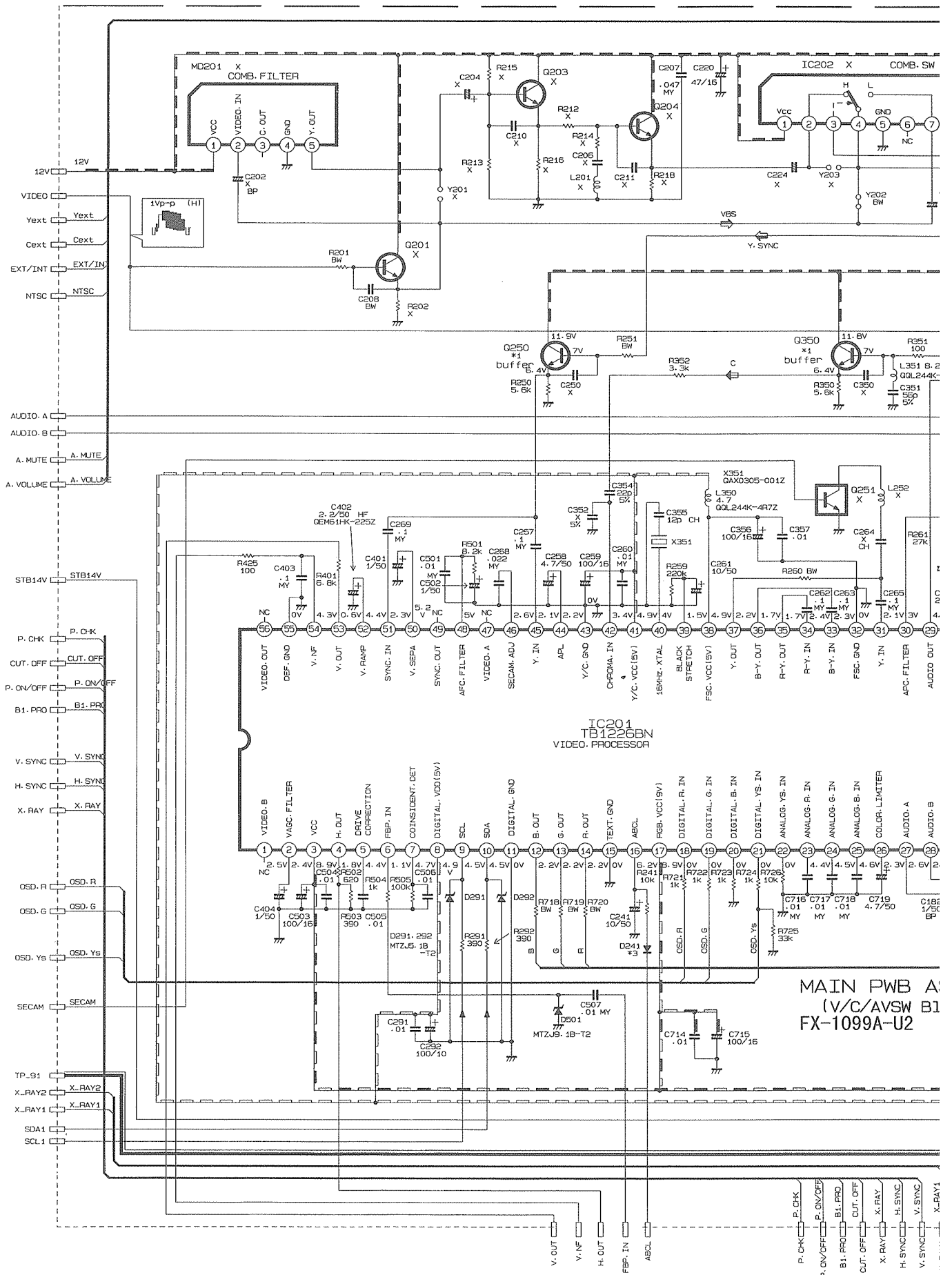

MAIN PWB A
(V/C/AVSW B1
FX-1099A-U2

-A14PN
14PN-K

TM-A14PN
TM-A14PN-K

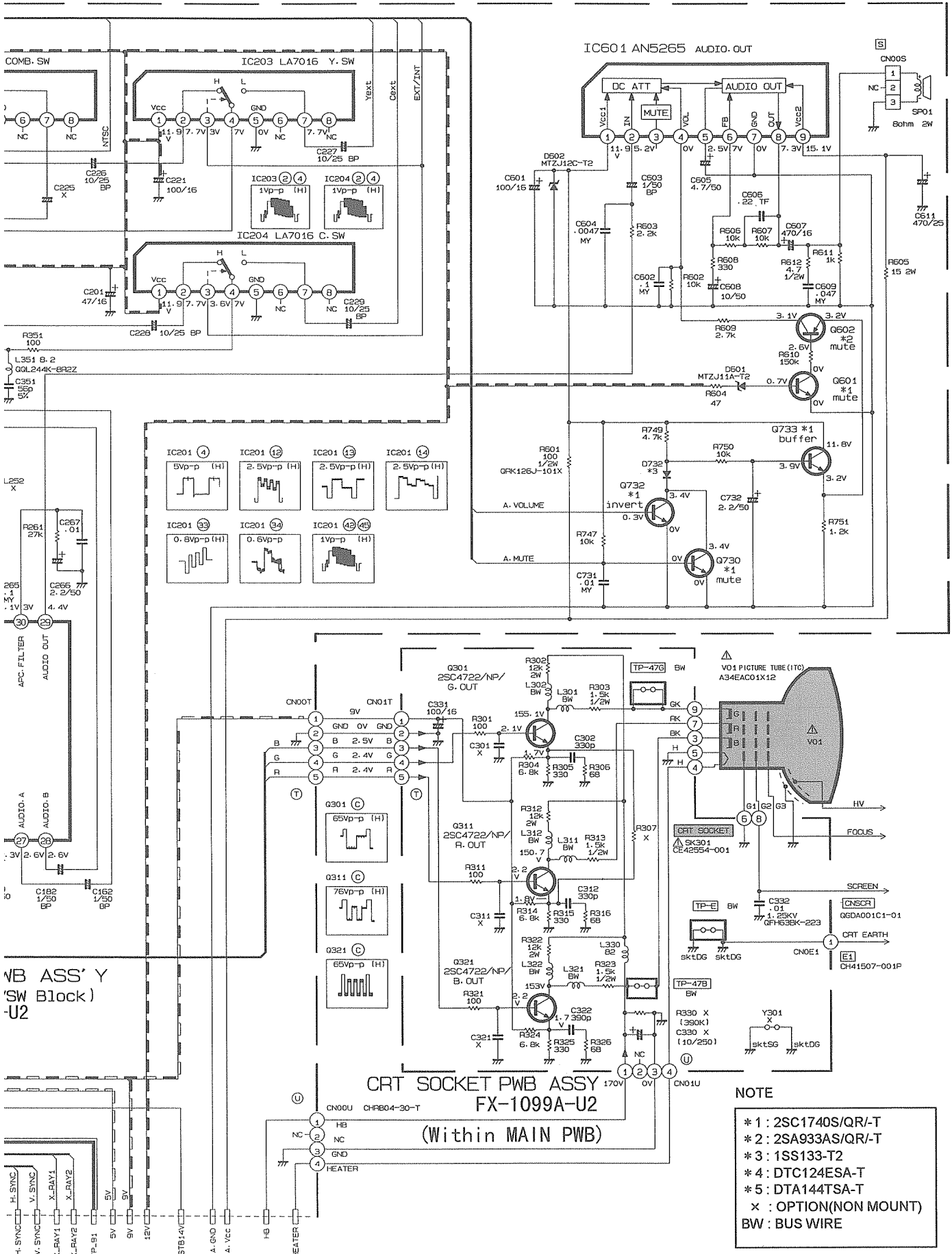

NOTE

- * 1 : 2SC1740S/QR-T
- * 2 : 2SA933AS/QR-T
- * 3 : 1SS133-T2
- * 4 : DTC124ESA-T
- * 5 : DTA144TSA-T
- X : OPTION(NON MOUNT)
- BW : BUS WIRE

MAIN PWB CIRCUIT DIAGRAM [Power & DEF. Circuit]

△ 3P INLET QMCO04-001

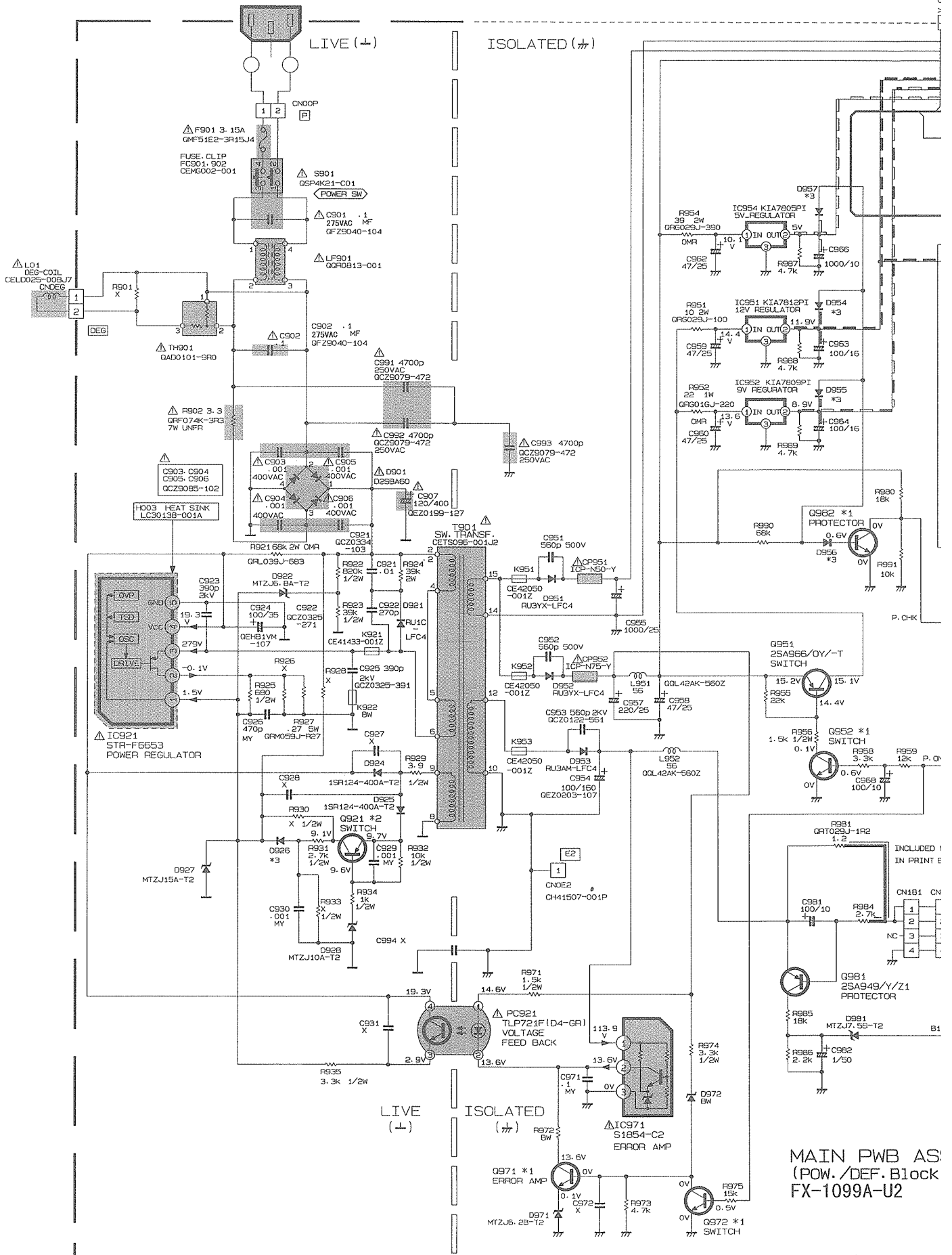

MAIN PWB AS:
(POW./DEF. Block
FX-1099A-U2

TM-A14PN
TM-A14PN-K

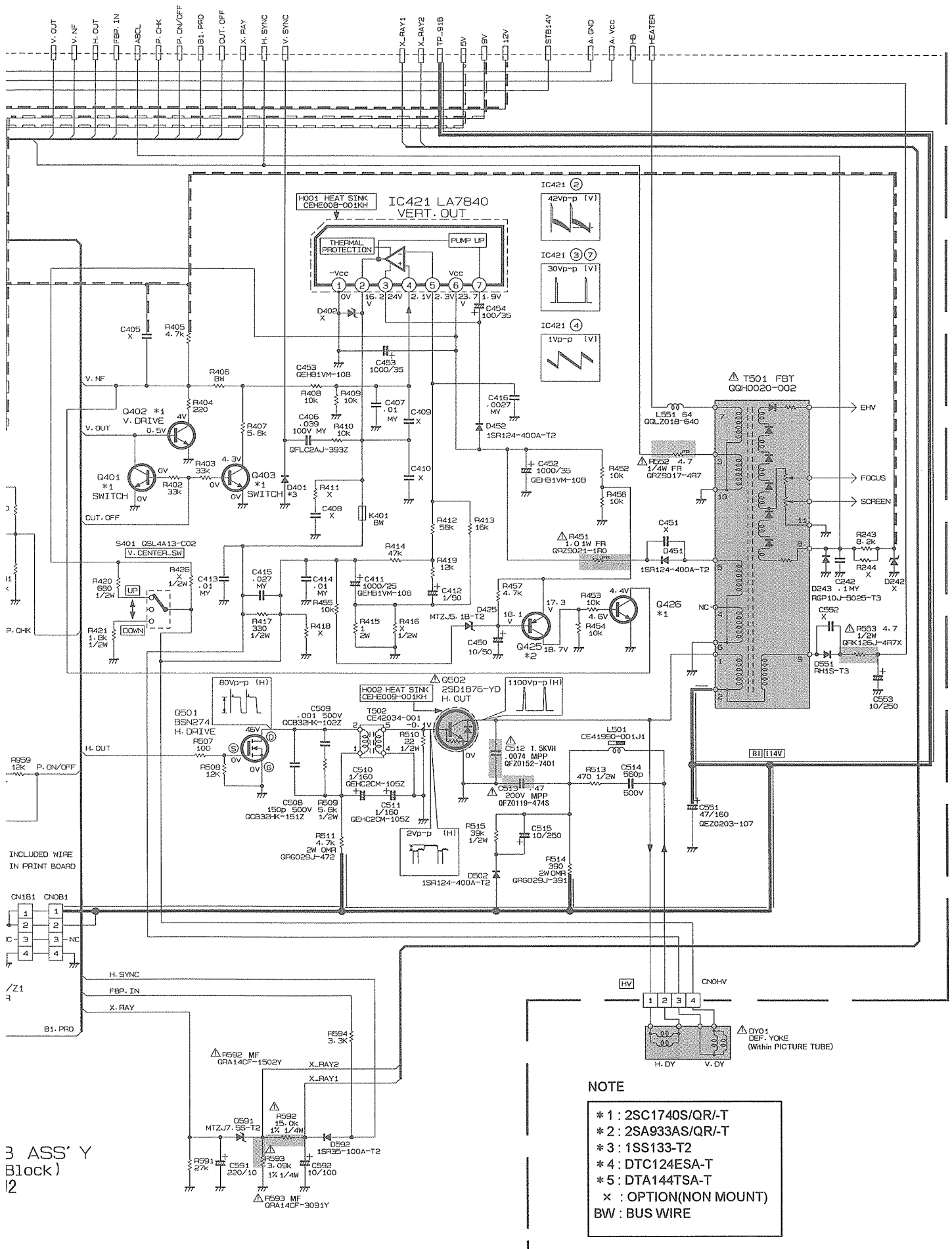

3 ASS' Y
Block)
I2

- NOTE**
- * 1 : 2SC1740S/QR-T
 - * 2 : 2SA933AS/QR-T
 - * 3 : 1SS133-T2
 - * 4 : DTC124ESA-T
 - * 5 : DTA144TSA-T
 - x : OPTION(NON MOUNT)
 - BW : BUS WIRE

PATTERN DIAGRAMS

MAIN PWB PATTERN

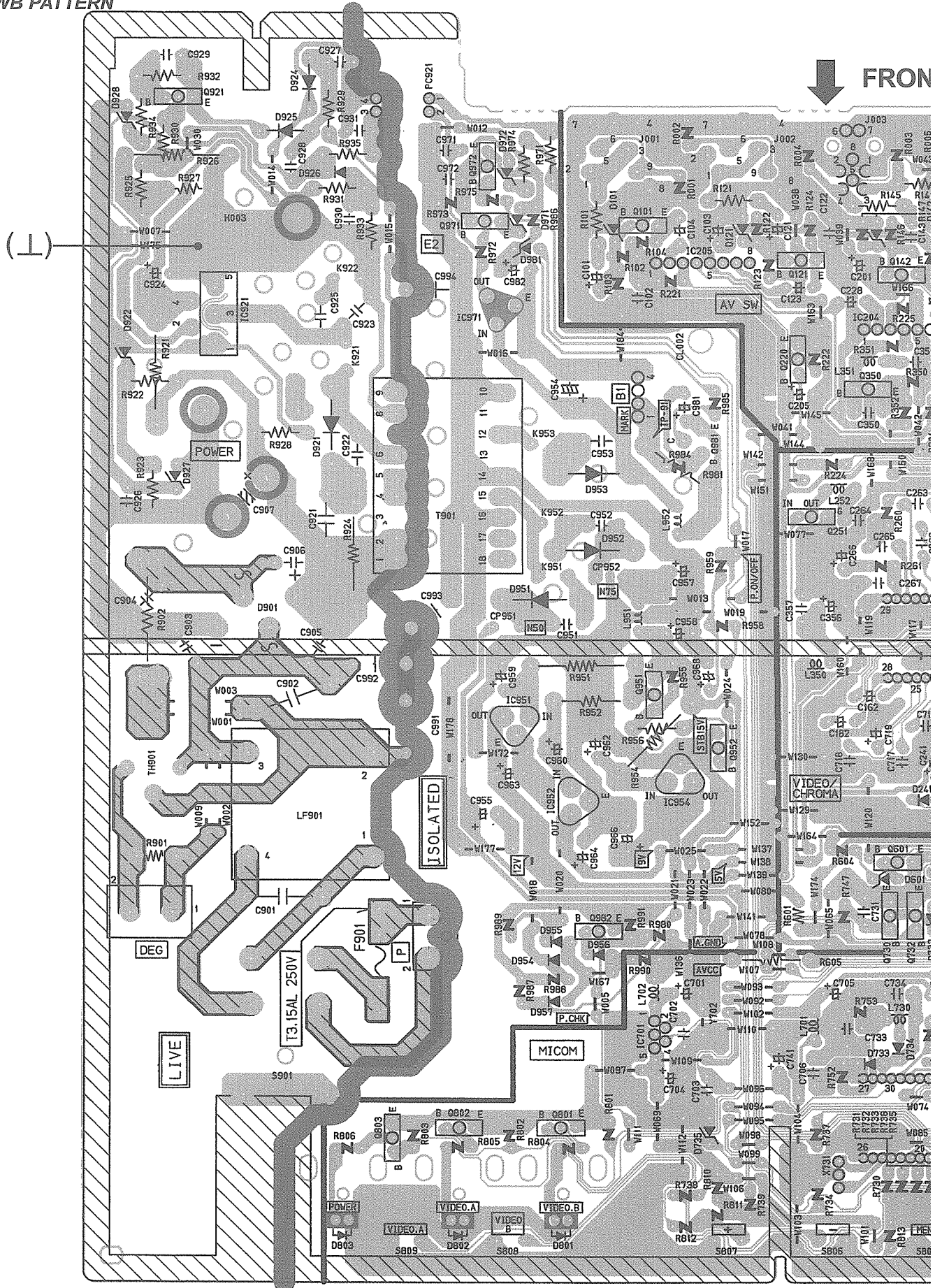

CRT SOCKET PWB PATTERN

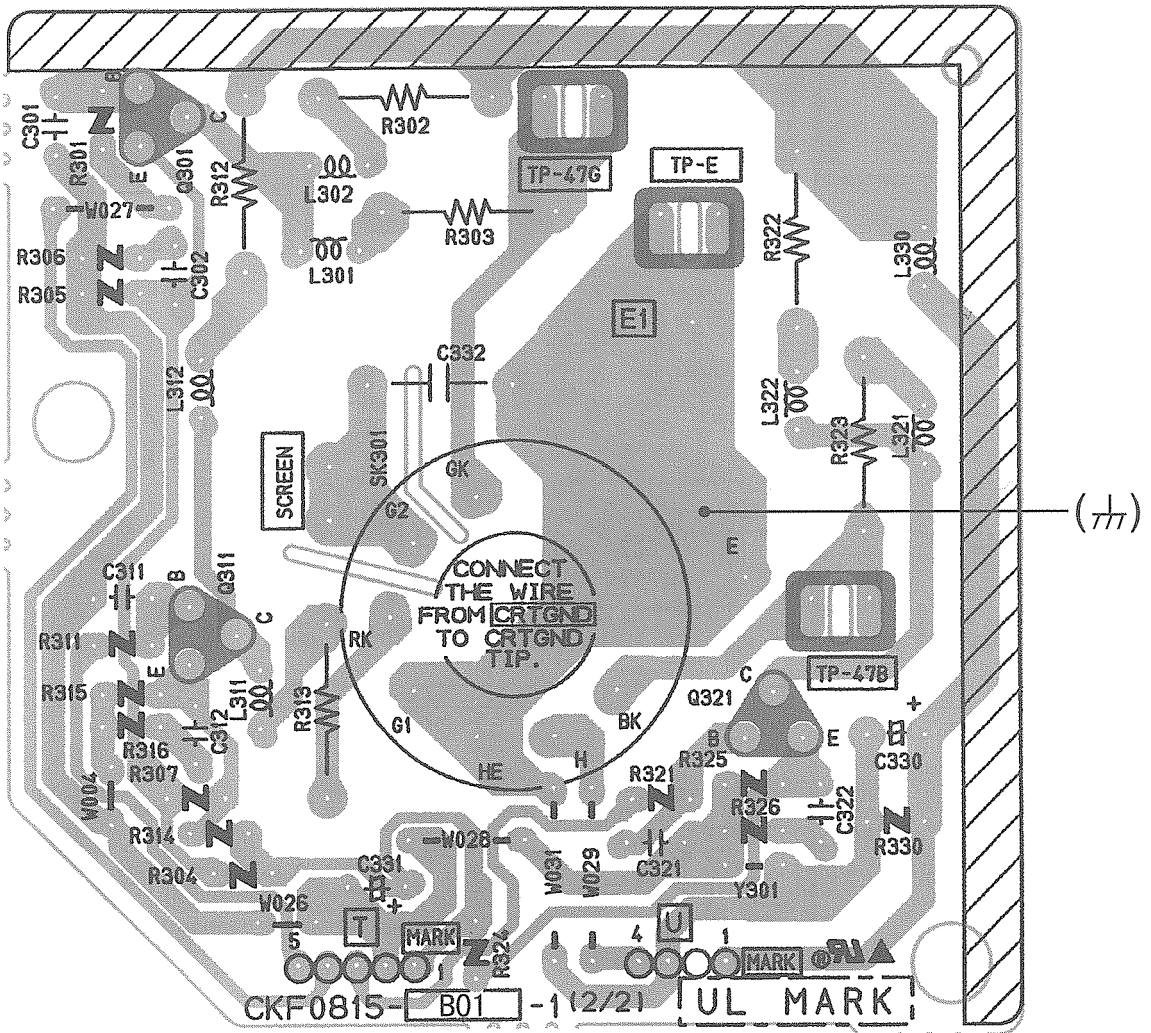

PARTS LIST

CAUTION

- The parts identified by the \triangle symbol are important for the safety. Whenever replacing these parts, be sure to use specified ones to secure the safety.
- The parts not indicated in this Parts List and those which are filled with lines — in the Parts No. columns will not be supplied.
- P. W. Board Ass'y will not be supplied, but those which are filled with the Parts No. in the Parts No. columns will be supplied.

ABBREVIATIONS OF RESISTORS, CAPACITORS AND TOLERANCES

RESISTORS		CAPACITORS	
C R	Carbon Resistor	C CAP.	Ceramic Capacitor
F R	Fusible Resistor	E CAP.	Electrolytic Capacitor
P R	Plate Resistor	M CAP.	Mylar Capacitor
V R	Variable Resistor	HV CAP.	High Voltage Capacitor
HV R	High Voltage Resistor	MF CAP.	Metalized Film Capacitor
MF R	Metal Film Resistor	MM CAP.	Metalized Mylar Capacitor
MG R	Metal Glazed Resistor	MP CAP.	Metalized Polystyrol Capacitor
MP R	Metal Plate Resistor	PP CAP.	Polypropylene Capacitor
OM R	Metal Oxide Film Resistor	PS CAP.	Polystyrol Capacitor
CMF R	Coating Metal Film Resistor	TF CAP.	Thin Film Capacitor
UNF R	Non-Flammable Resistor	MPP CAP.	Metalized Polypropylene Capacitor
CH V R	Chip Variable Resistor	TAN. CAP.	Tantalum Capacitor
CH MG R	Chip Metal Glazed Resistor	CH C CAP.	Chip Ceramic Capacitor
COMP. R	Composition Resistor	BP E CAP.	Bi-Polar Electrolytic Capacitor
LPTC R	Linear Positive Temperature Coefficient Resistor	CH AL E CAP.	Chip Aluminum Electrolytic Capacitor
		CH AL BP CAP.	Chip Aluminum Bi-Polar Capacitor
		CH TAN. E CAP.	Chip Tantalum Electrolytic Capacitor
		CH AL BP E CAP.	Chip Tantalum Bi-Polar Electrolytic Capacitor

TOLERANCES									
F	G	J	K	M	N	R	H	Z	P
±1%	±2%	±5%	±10%	±20%	±30%	+30%	+50%	+80%	+100%
						-10%	-10%	-20%	-0%

CONTENTS

■ EXPLODED VIEW PARTS LIST	32
■ EXPLODED VIEW	32
■ PRINTED WIRING BOARD PARTS LIST	
● MAIN PW BOARD ASS'Y (Within CRT SOCKET PW BOARD)	34
■ PACKING	41
■ PACKING PARTS LIST	41

EXPLODED VIEW PARTS LIST

△ Ref. No.	Part No.	Part Name	Description	Local
△ V01	A34EAC01X12	ITC TUBE (C)	Inc. DY, PC, WEDGE	*
△ L01	CELD025-008J7	DEG COIL		*
△ T1501	QQH0020-002	FB TRANSF.		
△ 1	LC10039-001C-HK	FRONT CABINET		*
2	CM48149-A01	JVC MARK		
3	CM46756-A01	POWER KNOB		
4	CM46757-001	SPRING		
5	LC20056-001A	CONTROL SHEET		
6	A48457-1	SPRING		*
7	CHGB0016-0A	BRAIDED WIRE		*
8	QQR0803-001	CORE FILTER		
10	CEBSS08P-01KJ2	SPEAKER	SP01	*
11	CM48241-001	KNOB CAP		
12	LC30150-002A-H	TERMINAL BRACKET		*
13	SBSB3012M	TAPPING SCREW	(× 4)	*
△ 14	QMCB004-001	3P INLET		
15	CM44287-00B	ASSY SCREW	(× 3)	
16	CHGT0035-0B	RECEP WIRE ASSY		
17	CHGT0014-BA-G	RECEP WIRE ASSY		
△ 18	LC10040-001B-HK	REAR COVER		*
19	GBSA4016N	TAPPING SCREW	(× 8)	*
△ 20	AEM2045-001-E	RATING LABEL	[TM-A14PN]	*
△ 20	AEM2041-003-E	RATING LABEL	[TM-A14PN-K]	*

EXPLODED VIEW

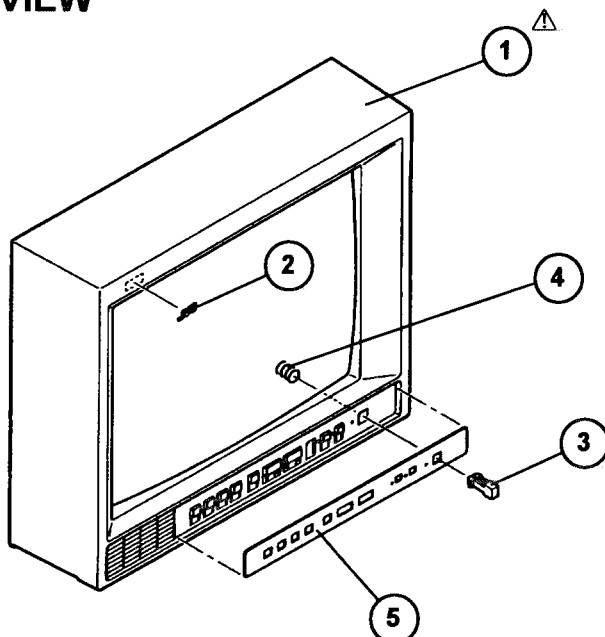

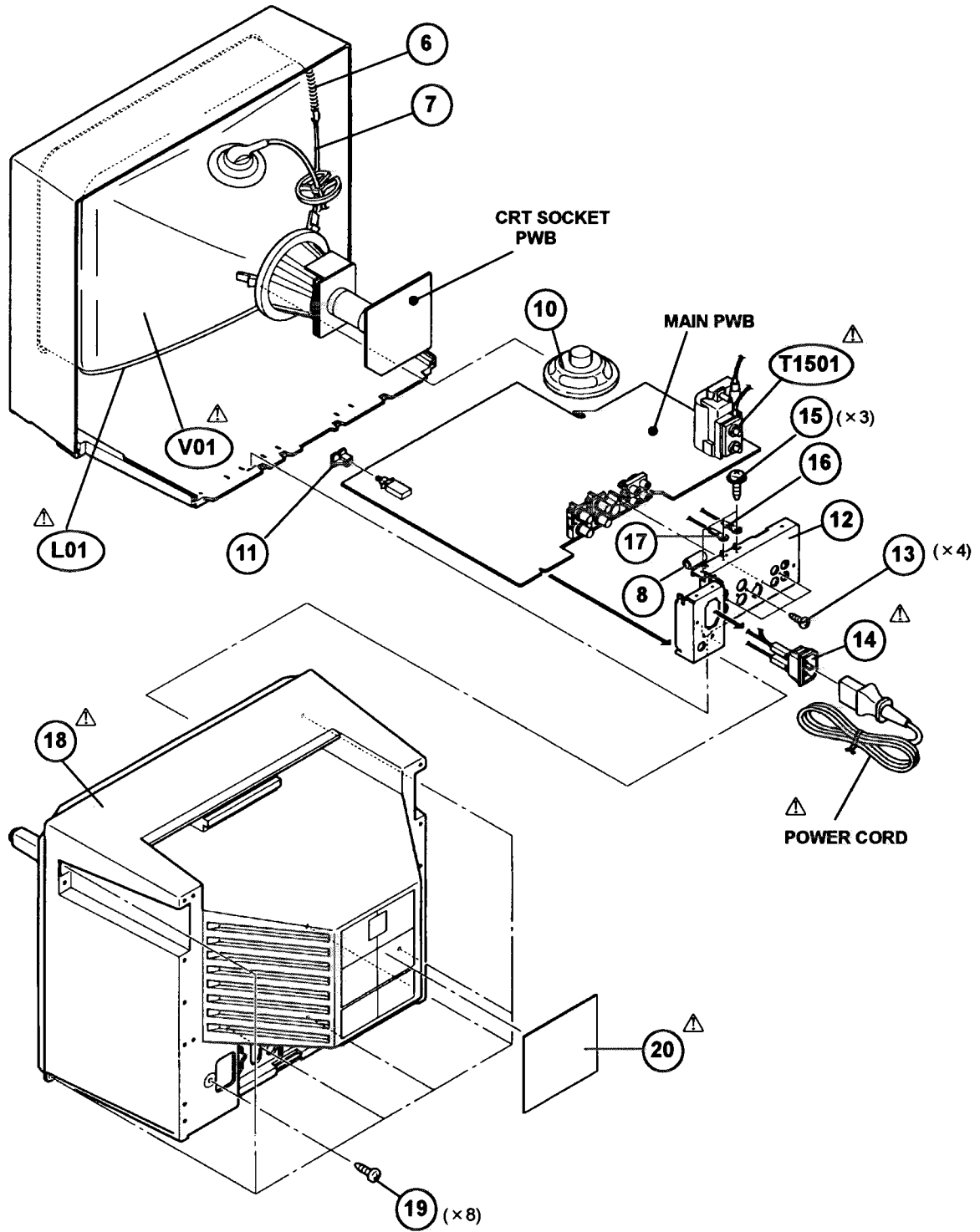

PRINTED WIRING BOARD PARTS LIST

MAIN PW BOARD ASS'Y (FX-1099A-U2)

△ Symbol No.	Part No.	Part Name	Description	Local
RESISTOR				
R1001-04	QRD161J-750Y	C R	75 Ω 1/6W J	*
R1101	QRD121J-101SY	C R	100 Ω 1/2W J	*
R1102	QRD161J-224Y	C R	220kΩ 1/6W J	*
R1103	QRD161J-104Y	C R	100kΩ 1/6W J	*
R1104	QRD161J-682Y	C R	6.8kΩ 1/6W J	*
R1121	QRD121J-101SY	C R	100 Ω 1/2W J	*
R1122	QRD161J-224Y	C R	220kΩ 1/6W J	*
R1123	QRD161J-104Y	C R	100kΩ 1/6W J	*
R1124	QRD161J-682Y	C R	6.8kΩ 1/6W J	*
R1141	QRD121J-101SY	C R	100 Ω 1/2W J	*
R1142	QRD161J-224Y	C R	220kΩ 1/6W J	*
R1143	QRD161J-104Y	C R	100kΩ 1/6W J	*
R1144	QRD161J-682Y	C R	6.8kΩ 1/6W J	*
R1145	QRD121J-101SY	C R	100 Ω 1/2W J	*
R1146	QRD161J-224Y	C R	220kΩ 1/6W J	*
R1147	QRD161J-104Y	C R	100kΩ 1/6W J	*
R1148	QRD161J-682Y	C R	6.8kΩ 1/6W J	*
R1161	QRD161J-223Y	C R	22kΩ 1/6W J	*
R1162-63	QRD161J-104Y	C R	100kΩ 1/6W J	*
R1164	QRD161J-472Y	C R	4.7kΩ 1/6W J	*
R1181	QRD161J-223Y	C R	22kΩ 1/6W J	*
R1182-83	QRD161J-104Y	C R	100kΩ 1/6W J	*
R1184	QRD161J-472Y	C R	4.7kΩ 1/6W J	*
R1221	QRD161J-683Y	C R	68kΩ 1/6W J	*
R1222	QRD161J-333Y	C R	33kΩ 1/6W J	*
R1223	QRD161J-103Y	C R	10kΩ 1/6W J	*
R1224	QRD161J-183Y	C R	18kΩ 1/6W J	*
R1225	QRD161J-333Y	C R	33kΩ 1/6W J	*
R1241	QRD161J-103Y	C R	10kΩ 1/6W J	*
R1243	QRD161J-822Y	C R	8.2kΩ 1/6W J	*
R1250	QRD161J-562Y	C R	5.6kΩ 1/6W J	*
R1259	QRD161J-224Y	C R	220kΩ 1/6W J	*
R1261	QRD161J-273Y	C R	27kΩ 1/6W J	*
R1291-92	QRD161J-391Y	C R	390 Ω 1/6W J	*
R1301	QRE141J-101Y	C R	100 Ω 1/4W J	*
R1302	QRG029J-123A	OM R	12kΩ 2W J	*
R1303	QRZ0107-152Z	C R	1.5kΩ 1/2W K	*
R1304	QRE141J-682Y	C R	6.8kΩ 1/4W J	*
R1305	QRD161J-331Y	C R	330 Ω 1/6W J	*
R1306	QRE141J-680Y	C R	68 Ω 1/4W J	*
R1311	QRE141J-101Y	C R	100 Ω 1/4W J	*
R1312	QRG029J-123A	OM R	12kΩ 2W J	*
R1313	QRZ0107-152Z	C R	1.5kΩ 1/2W K	*
R1314	QRE141J-682Y	C R	6.8kΩ 1/4W J	*
R1315	QRD161J-331Y	C R	330 Ω 1/6W J	*
R1316	QRE141J-680Y	C R	68 Ω 1/4W J	*
R1321	QRE141J-101Y	C R	100 Ω 1/4W J	*
R1322	QRG029J-123A	OM R	12kΩ 2W J	*
R1323	QRZ0107-152Z	C R	1.5kΩ	*
R1324	QRE141J-682Y	C R	6.8kΩ 1/4W J	*
R1325	QRD161J-331Y	C R	330 Ω 1/6W J	*
R1326	QRE141J-680Y	C R	68 Ω 1/4W J	*
R1350	QRD161J-562Y	C R	5.6kΩ 1/6W J	*
R1351	QRD161J-101Y	C R	100 Ω 1/6W J	*
R1352	QRE141J-332Y	C R	3.3kΩ 1/4W J	*
R1401	QRD161J-682Y	C R	6.8kΩ 1/6W J	*
R1402-03	QRD161J-333Y	C R	33kΩ 1/6W J	*
R1404	QRD161J-221Y	C R	220 Ω 1/6W J	*
R1405	QRD161J-472Y	C R	4.7kΩ 1/6W J	*
R1407	QRD161J-562Y	C R	5.6kΩ 1/6W J	*
R1408-10	QRD161J-103Y	C R	10kΩ 1/6W J	*
R1412	QRD161J-563Y	C R	56kΩ 1/6W J	*
R1413	QRD161J-163Y	C R	16kΩ 1/6W J	*
R1414	QRD161J-473Y	C R	47kΩ 1/6W J	*
R1415	QRT029J-1R0	MF R	1.0 Ω 2W J	*
R1417	QRD121J-331SY	C R	330 Ω 1/2W J	*

△ Symbol No.	Part No.	Part Name	Description	Local
RESISTOR				
	R1419	QRD161J-123Y	C R 12kΩ 1/6W J	*
	R1420	QRD121J-681SY	C R 680 Ω 1/2W J	*
	R1421	QRD121J-182SY	C R 1.8kΩ 1/2W J	*
	R1425	QRD161J-101Y	C R 100 Ω 1/6W J	*
	R1426	QRE121J-681Y	C R 680Ω 1/2W J	*
△	R1451	QRZ9021-1R0	F R 1.0 Ω 1W J	*
	R1452-56	QRD161J-103Y	C R 10kΩ 1/6W J	*
	R1457	QRD161J-472Y	C R 4.7kΩ 1/6W J	*
	R1501	QRE141J-822Y	C R 8.2kΩ 1/4W J	*
	R1502	QRE141J-101Y	C R 100Ω 1/4W J	*
	R1503	QRE141J-332Y	C R 3.3kΩ 1/4W J	*
	R1504	QRD161J-103Y	C R 10kΩ 1/6W J	*
	R1505	QRD161J-104Y	C R 100kΩ 1/6W J	*
	R1507	QRD161J-101Y	C R 100 Ω 1/6W J	*
	R1509	QRD121J-562SY	C R 5.6kΩ 1/2W J	*
	R1510	QRD121J-220SY	C R 22 Ω 1/2W J	*
	R1511	QRG029J-472	OM R 4.7kΩ 2W J	*
	R1513	QRD121J-471SY	C R 470 Ω 1/2W J	*
	R1514	QRG029J-391	OM R 390 Ω 2W J	*
	R1515	QRD121J-393SY	C R 39kΩ 1/2W J	*
△	R1552	QRZ9017-4R7	F R 4.7 Ω 1/4W J	*
△	R1553	QRK126J-4R7X	C R 4.7Ω 1/2W J	*
	R1591	QRD161J-273Y	C R 27kΩ 1/6W J	*
△	R1592	QRA14CF-1502Y	MF R 15kΩ 1/4W F	*
△	R1593	QRA14CF-3091Y	MF R 3.09kΩ 1/4W F	*
	R1594	QRD161J-332Y	C R 3.3kΩ 1/6W J	*
	R1601	QRD120J-151SX	C R 150 Ω 1/2W J	*
	R1602	QRD161J-103Y	C R 10kΩ 1/6W J	*
	R1603	QRD161J-222Y	C R 2.2kΩ 1/6W J	*
	R1604	QRD161J-470Y	C R 47 Ω 1/6W J	*
	R1605	QRG029J-150A	OM R 15 Ω 2W J	*
	R1606-07	QRD161J-103Y	C R 10kΩ 1/6W J	*
	R1608	QRD161J-331Y	C R 330 Ω 1/6W J	*
	R1609	QRD161J-272Y	C R 2.7kΩ 1/6W J	*
	R1610	QRD161J-154Y	C R 150kΩ 1/6W J	*
	R1611	QRD161J-102Y	C R 1kΩ 1/6W J	*
	R1612	QRD121J-4R7SY	C R 4.7 Ω 1/2W J	*
	R1710	QRD161J-222Y	C R 2.2kΩ 1/6W J	*
	R1711	QRD161J-102Y	C R 1kΩ 1/6W J	*
	R1712	QRD161J-222Y	C R 2.2kΩ 1/6W J	*
	R1714	QRD161J-222Y	C R 2.2kΩ 1/6W J	*
	R1715	QRD161J-102Y	C R 1kΩ 1/6W J	*
	R1716	QRD161J-222Y	C R 2.2kΩ 1/6W J	*
	R1717	QRD161J-102Y	C R 1kΩ 1/6W J	*
	R1721-24	QRD161J-102Y	C R 1kΩ 1/6W J	*
	R1725	QRD161J-333Y	C R 33kΩ 1/6W J	*
	R1726	QRD161J-103Y	C R 10kΩ 1/6W J	*
	R1734	QRD161J-823Y	C R 82kΩ 1/6W J	*
	R1735	QRD161J-561Y	C R 560 Ω 1/6W J	*
	R1736	QRD161J-682Y	C R 6.8kΩ 1/6W J	*
	R1737	QRD161J-561Y	C R 560 Ω 1/6W J	*
	R1738-40	QRD161J-221Y	C R 220 Ω 1/6W J	*
	R1744	QRD161J-103Y	C R 10kΩ 1/6W J	*
	R1745	QRD161J-682Y	C R 6.8kΩ 1/6W J	*
	R1747	QRD161J-103Y	C R 10kΩ 1/6W J	*
	R1749	QRD161J-472Y	C R 4.7kΩ 1/6W J	*
	R1750	QRD161J-103Y	C R 10kΩ 1/6W J	*
	R1751	QRD161J-122Y	C R 1.2kΩ 1/6W J	*
	R1752-54	QRD161J-682Y	C R 6.8kΩ 1/6W J	*
	R1756	QRB089J-103	NETW. R 10kΩ	*
	R1758	QRB089J-103	NETW. R 10kΩ	*
	R1759	QRD161J-221Y	C R 220 Ω 1/6W J	*
	R1763	QRD161J-221Y	C R 220 Ω 1/6W J	*
	R1773	QRD161J-682Y	C R 6.8kΩ 1/6W J	*
	R1774	QRD161J-102Y	C R 1kΩ 1/6W J	*
	R1775-76	QRD161J-682Y	C R 6.8kΩ 1/6W J	*
	R1779-80	QRD161J-103Y	C R 10kΩ 1/6W J	*
	R1781-82	QRD161J-223Y	C R 22kΩ 1/6W J	*

△ Symbol No.	Part No.	Part Name	Description	Local
RESISTOR				
R1783	QRD161J-153Y	C R	15kΩ 1/6W J	*
R1784	QRD161J-563Y	C R	56kΩ 1/6W J	*
R1785	QRD161J-101Y	C R	100 Ω 1/6W J	*
R1786-90	QRD161J-221Y	C R	220 Ω 1/6W J	*
R1801-02	QRD161J-103Y	C R	10kΩ 1/6W J	*
R1804-06	QRD161J-681Y	C R	680 Ω 1/6W J	*
R1807	QRD161J-472Y	C R	4.7kΩ 1/6W J	*
R1808	QRD161J-332Y	C R	3.3kΩ 1/6W J	*
R1809	QRD161J-562Y	C R	5.6kΩ 1/6W J	*
R1810	QRD161J-472Y	C R	4.7kΩ 1/6W J	*
R1811	QRD161J-332Y	C R	3.3kΩ 1/6W J	*
R1812	QRD161J-562Y	C R	5.6kΩ 1/6W J	*
R1813	QRD161J-472Y	C R	4.7kΩ 1/6W J	*
R1814	QRD161J-332Y	C R	3.3kΩ 1/6W J	*
R1815	QRD161J-562Y	C R	5.6kΩ 1/6W J	*
△ R1902	QRF074K-3R3	UNF R	3.3 Ω 7W K	*
R1921	QRG039J-683A	OM R	68kΩ 3W J	*
R1922	QRD121J-824SY	C R	820kΩ 1/2W J	*
R1923	QRD121J-393SY	C R	39kΩ 1/2W J	*
R1924	QRG029J-393	OM R	39kΩ 2W J	*
R1925	QRD121J-681SY	C R	680 Ω 1/2W J	*
R1927	QRM059J-R27	MP R	0.27 Ω 5W J	*
R1929	QRD121J-3R9SY	C R	3.9 Ω 1/2W J	*
R1931	QRD121J-272SY	C R	2.7kΩ 1/2W J	*
R1932	QRD121J-103SY	C R	10kΩ 1/2W J	*
R1934	QRD121J-102SY	C R	1kΩ 1/2W J	*
R1935	QRD121J-332SY	C R	3.3kΩ 1/2W J	*
R1951	QRG029J-100	OM R	10 Ω 2W J	*
R1952	QRG019J-220S	OM R	22 Ω 1W J	*
R1954	QRG029J-390	OM R	39 Ω 2W J	*
R1955	QRD161J-223Y	C R	22kΩ 1/6W J	*
R1956	QRD121J-152SY	C R	1.5kΩ 1/2W J	*
R1958	QRD161J-332Y	C R	3.3kΩ 1/6W J	*
R1959	QRD161J-123Y	C R	12kΩ 1/6W J	*
R1971	QRD121J-152SY	C R	1.5kΩ 1/2W J	*
R1973	QRD161J-472Y	C R	4.7kΩ 1/6W J	*
R1974	QRD121J-332SY	C R	3.3kΩ 1/2W J	*
R1975	QRD161J-153Y	C R	15kΩ 1/6W J	*
R1980	QRD161J-183Y	C R	18kΩ 1/6W J	*
R1981	QRX029J-1R2A	MF R	1.2 Ω 2W J	*
R1984	QRD161J-272Y	C R	2.7kΩ 1/6W J	*
R1985	QRD161J-183Y	C R	18kΩ 1/6W J	*
R1986	QRD161J-222Y	C R	2.2kΩ 1/6W J	*
R1987-89	QRD161J-472Y	C R	4.7kΩ 1/6W J	*
R1990	QRD161J-683Y	C R	68kΩ 1/6W J	*
R1991	QRD161J-103Y	C R	10kΩ 1/6W J	*
CAPACITOR				
C1101	QETN1HM-106Z	E CAP.	10 μF 50V M	*
C1102	QFLC1HJ-473MZ	M CAP.	0.047 μF 50V J	*
C1103	QETN1CM-107Z	E CAP.	100 μF 16V M	*
C1104	QENC1EM-106Z	BP E CAP.	10 μF 25V M	*
C1121	QETN1HM-106Z	E CAP.	10 μF 50V M	*
C1122	QFLC1HJ-473MZ	M CAP.	0.047 μF 50V J	*
C1123	QENC1EM-106Z	BP E CAP.	10 μF 25V M	*
C1141	QETN1HM-106Z	E CAP.	10 μF 50V M	*
C1142	QFLC1HJ-473MZ	M CAP.	0.047 μF 50V J	*
C1143	QFLC1HJ-103MZ	M CAP.	0.01 μF 50V J	*
C1144	QFLC1HJ-473MZ	M CAP.	0.047 μF 50V J	*
C1161-62	QENC1HM-105Z	BP E CAP.	1 μF 50V M	*
C1181-82	QENC1HM-105Z	BP E CAP.	1 μF 50V M	*
C1201	QETN1CM-476Z	E CAP.	47 μF 16V M	*
C1205	QETN1CM-107Z	E CAP.	100 μF 16V M	*
C1207	QFLC1HJ-473MZ	M CAP.	0.047 μF 50V J	*
C1220	QETN1CM-476Z	E CAP.	47 μF 16V M	*
C1221	QETN1CM-107Z	E CAP.	100 μF 16V M	*
C1226-29	QENC1EM-106Z	BP E CAP.	10 μF 25V M	*
C1241	QETN1HM-106Z	E CAP.	10 μF 50V M	*
C1242	QFLC1HJ-104MZ	M CAP.	0.1 μF 50V J	*
C1257	QFLC1HJ-104MZ	M CAP.	0.1 μF 50V J	*

△ Symbol No.	Part No.	Part Name	Description	Local
CAPACITOR				
C1258	QETN1HM-475Z	E CAP.	4.7 μ F 50V M	*
C1259	QETN1CM-107Z	E CAP.	100 μ F 16V M	*
C1260	QFLC1HJ-103MZ	M CAP.	0.01 μ F 50V J	*
C1261	QETN1HM-106Z	E CAP.	10 μ F 50V M	*
C1262-63	QFLC1HJ-104MZ	M CAP.	0.1 μ F 50V J	*
C1265	QFLC1HJ-104MZ	M CAP.	0.1 μ F 50V J	*
C1266	QETN1HM-225Z	E CAP.	2.2 μ F 50V M	*
C1267	QCY31HK-103Z	CH C CAP.	0.01 μ F 50V K	*
C1268	QFLC1HJ-223MZ	M CAP.	0.022 μ F 50V J	*
C1269	QFLC1HJ-104MZ	M CAP.	0.1 μ F 50V J	*
C1291	QCY31HK-103Z	CH C CAP.	0.01 μ F 50V K	*
C1292	QETN1AM-107Z	E CAP.	100 μ F 10V M	*
C1302	QCS31HJ-331Z	C CAP.	330pF 50V J	*
C1312	QCS31HJ-331Z	C CAP.	330pF 50V J	*
C1322	QCS31HJ-391Z	C CAP.	390pF 50V J	*
C1331	QETN1CM-107Z	E CAP.	100 μ F 16V M	*
C1332	QFH63BK-223M	MM CAP.	0.022 μ F 1250V K	*
C1351	QCS31HJ-560Z	C CAP.	56pF 50V J	*
C1354	QCS31HJ-220Z	C CAP.	22pF 50V J	*
C1355	QCT25CH-120Z	C CAP.	12 p F 50V J	*
C1356	QETN1CM-107Z	E CAP.	100 μ F 16V M	*
C1357	QCY31HK-103Z	CH C CAP.	0.01 μ F 50V K	*
C1401	QETN1HM-105Z	E CAP.	1 μ F 50V M	*
C1402	QEM61HK-225MZ	E CAP.	2.2 μ F 50V K	*
C1403	QFLC1HJ-104MZ	M CAP.	0.1 μ F 50V J	*
C1404	QETN1HM-105Z	E CAP.	1 μ F 50V M	*
C1406	QFLC2AJ-393MZ	M CAP.	0.039 μ F 100V J	*
C1407	QFLC1HJ-103MZ	M CAP.	0.01 μ F 50V J	*
C1411	QEHB1VM-108M	E CAP.	1000 μ F 35V M	*
C1412	QETN1HM-105Z	E CAP.	1 μ F 50V M	*
C1413	QFLC2AJ-103Z	M CAP.	0.01 μ F 100V J	*
C1414	QFLC1HJ-103Z	M CAP.	0.01 μ F 50V J	*
C1415	QFLC1HJ-683Z	M CAP.	0.068 μ F 50V J	*
C1416	QFLC1HJ-272Z	M CAP.	2700pF 50V J	*
C1450	QETN1HM-106Z	E CAP.	10 μ F 50V M	*
C1452-53	QEHB1VM-108M	E CAP.	1000 μ F 35V M	*
C1454	QETN1VM-107Z	E CAP.	100 μ F 35V M	*
C1501	QFLC1HJ-103Z	M CAP.	0.01 μ F 50V J	*
C1502	QETN1HM-105Z	E CAP.	1 μ F 50V M	*
C1503	QETN1CM-107Z	E CAP.	100 μ F 16V M	*
C1504-06	QCY31HK-103Z	CH C CAP.	0.01 μ F 50V K	*
C1507	QFLC1HJ-103MZ	M CAP.	0.01 μ F 50V J	*
C1508	QCY32HK-151RZ	CH C CAP.	150 p F 500V K	*
C1509	QCY32HK-102RZ	CH C CAP.	1000 p F 500V K	*
C1510-11	QEHC2CM-105MZ	E CAP.	1 μ F 160V M	*
△ C1512	QFZ0152-7401	MPP CAP.	7400 p F1.5kVH \pm 2.5%	*
△ C1513	QFZ0119-474S	MPP CAP.	0.47 μ F 200V \pm 3%	*
C1514	QCB32HK-561Z	C CAP.	560pF 500V K	*
C1515	QETN2EM-106Z	E CAP.	10 μ F 250V M	*
C1551	QEZO203-107	E CAP.	100 μ F 160V M	*
C1553	QETN2EM-106Z	E CAP.	10 μ F 250V M	*
C1591	QETN1AM-227Z	E CAP.	220 μ F 10V M	*
C1592	QETN2AM-106Z	E CAP.	10 μ F 100V M	*
C1601	QETN1CM-107Z	E CAP.	100 μ F 16V M	*
C1602	QFLC1HJ-104MZ	M CAP.	0.1 μ F 50V J	*
C1603	QENC1HM-105Z	BP E CAP.	1 μ F 50V M	*
C1604	QFLC1HJ-472MZ	M CAP.	4700 p F	*
C1605	QETN1HM-475Z	E CAP.	4.7 μ F 50V M	*
C1606	QFV71HJ-224MZ	TF CAP.	0.22 μ F 50V J	*
C1607	QETN1CM-477Z	E CAP.	470 μ F 16V M	*
C1608	QETN1HM-106Z	E CAP.	10 μ F 50V M	*
C1609	QFLC1HJ-473MZ	M CAP.	0.047 μ F 50V J	*
C1611	QETN1EM-477Z	E CAP.	470 μ F 25V M	*
C1701	QETN1CM-476Z	E CAP.	47 μ F 16V M	*
C1702	QFLC1HJ-104MZ	M CAP.	0.1 μ F 50V J	*
C1703	QFLC1HJ-103MZ	M CAP.	0.01 μ F 50V J	*
C1704-05	QETN1AM-107Z	E CAP.	100 μ F 10V M	*
C1706	QFV71HJ-124MZ	TF CAP.	0.12 μ F 50V J	*

△ Symbol No.	Part No.	Part Name	Description	Local
CAPACITOR				
C1707	QFLC1HJ-103MZ	M CAP.	0.01 μF 50V J	*
C1714	QCY31HK-103Z	CH C CAP.	0.01 μF 50V K	*
C1715	QETN1CM-107Z	E CAP.	100 μF 16V M	*
C1716-18	QFLC1HJ-103MZ	M CAP.	0.01 μF 50V J	*
C1719	QETN1HM-475Z	E CAP.	4.7 μF 50V M	*
C1731	QFLC1HJ-103Z	M CAP.	0.01 μF 50V J	*
C1732	QETN1HM-225Z	E CAP.	2.2 μF 50V M	*
C1733	QCT25CH-560Z	C CAP.	56 pF 50V J	*
C1734	QCT25CH-680Z	C CAP.	68 pF 50V J	*
C1735	QETN1CM-476Z	E CAP.	47 μF 16V M	*
C1736	QFLC1HJ-103Z	M CAP.	0.01 μF 50V J	*
C1738	QFLC1HJ-102MZ	M CAP.	1000 pF 50V J	*
C1739	QFLC1HJ-103MZ	M CAP.	0.01 μF 50V J	*
C1740	QCS31HJ-560Z	C CAP.	56pF 50V J	*
C1741	QETN1HM-106Z	E CAP.	10 μF 50V M	*
△ C1901	QFZ9040-104	MF CAP.	0.1 μFAC275V M	*
△ C1902	QFZ9040-104	MF CAP.	0.1 μFAC275V M	*
△ C1903	QCZ9085-102	C CAP.	1000 pFAC400V M	*
△ C1904	QCZ9085-102	C CAP.	1000 pFAC400V M	*
△ C1905	QCZ9085-102	C CAP.	1000 pFAC400V M	*
△ C1906	QCZ9085-102	C CAP.	1000 pFAC400V M	*
△ C1907	QEZO199-127	E CAP.	120 μF 400V ±3%	*
C1921	QCF22HP-103M	CH C CAP.	0.01 μF 500V P	*
C1922	QCZO122-271U	C CAP.	270 pF 2kV K	*
C1923	QCZO122-391A	C CAP.	390 pF 2kV K	*
C1924	QEBB1VM-107M	E CAP.	100 μF 35V M	*
C1925	QCZO122-391U	C CAP.	390 pF 2kV K	*
C1926	QFLC1HJ-471MZ	M CAP.	470 pF 50V J	*
C1929-30	QFLC1HJ-102MZ	M CAP.	1000 pF 50V J	*
C1951-52	QCY32HK-561RZ	CH C CAP.	560 pF 500V K	*
C1953	QCZO122-561A	C CAP.	560 pF 2kV K	*
C1954	QEZO203-107	E CAP.	100 μF 160V M	*
C1955	QETN1EM-108Z	E CAP.	1000 μF 25V M	*
C1957	QETN1EM-227Z	E CAP.	220 μF 25V M	*
C1958-60	QETN1EM-476Z	E CAP.	47 μF 25V M	*
C1962	QETN1EM-476Z	E CAP.	47 μF 25V M	*
C1963-64	QETN1CM-107Z	E CAP.	100 μF 16V M	*
C1966	QETN1AM-108Z	E CAP.	1000 μF 10V M	*
C1968	QETN1AM-107Z	E CAP.	100 μF 10V M	*
C1971	QFLC1HJ-104MZ	M CAP.	0.1 μF 50V J	*
C1981	QETN1AM-107Z	E CAP.	100 μF 10V M	*
C1982	QETN1HM-105Z	E CAP.	1 μF 50V M	*
△ C1991	QCZ9079-472	C CAP.	4700 pFAC250V M	*
△ C1992	QCZ9079-472	C CAP.	4700 pFAC250V M	*
△ C1993	QCZ9079-472	C CAP.	4700 pFAC250V M	*
TRANSFORMER				
△ T1501	QQH0020-002	FB TRANSF.		*
T1502	CE42034-001	H. DRIVE TRANSF.		*
△ T1901	CETS096-001J2	SWITCH. TRANSF.		*
COIL				
L1330	QQL244K-820Z	COIL	82 μH K	*
L1350	QQL244K-4R7Z	COIL	4.7 μH K	*
L1351	QQL244K-8R2Z	COIL	8.2 μH K	*
L1501	CE41990-001J1	LINEARITY COIL		*
L1551	CELC901-064J6	HEATER CHOKE		*
L1701	QQL244K-4R7Z	COIL	4.7 μH K	*
L1730	QQL244K-8R2Z	COIL	8.2 μH K	*
L1951-52	CELC058-560Z	CHOKE COIL		*
DIODE				
D1101	MTZJ12C-T2	ZENER DIODE		*
D1121	MTZJ12C-T2	ZENER DIODE		*
D1141-42	MTZJ12C-T2	ZENER DIODE		*
D1161	MTZJ12C-T2	ZENER DIODE		*
D1181	MTZJ12C-T2	ZENER DIODE		*
D1224-25	1SS133-T2	SI. DIODE		*
D1241	1SS133-T2	SI. DIODE		*
D1243	RGP10J-5025-T3	SI. DIODE		*
D1291-92	MTZJ5.1B-T2	ZENER DIODE		*

△ Symbol No.	Part No.	Part Name	Description	Local
D I O D E				
D1401	1SS133-T2	SI. DIODE		*
D1425	MTZJ5. 1B-T2	ZENER DIODE		*
D1451-52	1SR124-400A-T2	SI. DIODE		*
D1501	MTZJ9. 1B-T2	ZENER DIODE		*
D1502	1SR124-400A-T2	SI. DIODE		*
D1551	RH1S-T3	SI. DIODE		*
D1591	MTZJ7. 5S-T2	ZENER DIODE		*
D1592	1SR35-100A-T2	SI. DIODE		*
D1601	MTZJ11A-T2	ZENER DIODE		*
D1602	MTZJ12C-T2	ZENER DIODE		*
D1732	1SS133-T2	SI. DIODE		*
D1733-34	MA700A-T2	SI. DIODE		*
D1735	MTZJ5. 1B-T2	ZENER DIODE		*
D1743-45	MTZJ5. 1B-T2	ZENER DIODE		*
D1801	GL2EG6	L. E. D. (GRN)	VIDEO. B	
D1802	GL2EG6	L. E. D. (GRN)	VIDEO. A	
D1803	GL2EG6	L. E. D. (GRN)	POWER	
△ D1901	D2SBA60	BRIDGE DIODE		*
D1921	RU1C-LFC4	SI. DIODE		*
D1922	MTZJ6. 8A-T2	ZENER DIODE		*
D1924-25	1SR124-400A-T2	SI. DIODE		*
D1926	1SS133-T2	SI. DIODE		*
D1927	MTZJ15A-T2	ZENER DIODE		*
D1928	MTZJ10A-T2	ZENER DIODE		*
D1951-52	RU3YX-LFC4	SI. DIODE		*
D1953	RU3AM-LFC4	SI. DIODE		*
D1954-57	1SS133-T2	SI. DIODE		*
D1971	MTZJ6. 2B-T2	ZENER DIODE		*
D1981	MTZJ7. 5S-T2	ZENER DIODE		*
T R A N S I S T O R				
Q1101	2SA933AS/QR/T	SI. TRANSISTOR		*
Q1121	2SA933AS/QR/-T	SI. TRANSISTOR		*
Q1141-42	2SA933AS/QR/-T	SI. TRANSISTOR		*
Q1161	2SC1740S/QR/-T	SI. TRANSISTOR		*
Q1181	2SC1740S/QR/-T	SI. TRANSISTOR		*
Q1220	2SC1740S/QR/-T	SI. TRANSISTOR		*
Q1223	DTC124ESA-T	DIGI. TRANSISTOR		*
Q1250	2SC1740S/QR/-T	SI. TRANSISTOR		*
Q1301	2SC4722/NP/	SI. TRANSISTOR		*
Q1311	2SC4722/NP/	SI. TRANSISTOR		*
Q1321	2SC4722/NP/	SI. TRANSISTOR		*
Q1350	2SC1740S/QR/-T	SI. TRANSISTOR		*
Q1401-03	2SC1740S/QR/-T	SI. TRANSISTOR		*
Q1425	2SA933AS/QR/-T	SI. TRANSISTOR		*
Q1426	2SC1740S/QR/-T	SI. TRANSISTOR		*
Q1501	BSN274	F. E. T.		*
△ Q1502	2SD1876-YD	SI. TRANSISTOR	H. OUT	*
Q1601	2SC1740S/QR/-T	SI. TRANSISTOR		*
Q1602	2SA933AS/QR/-T	SI. TRANSISTOR		*
Q1730	2SC1740S/QR/-T	SI. TRANSISTOR		*
Q1732-35	2SC1740S/QR/-T	SI. TRANSISTOR		*
Q1801-03	DTA144TSA-T	DIGI. TRANSISTOR		*
Q1921	2SA933AS/QR/-T	SI. TRANSISTOR		*
Q1951	2SA966/OY/-T	SI. TRANSISTOR		*
Q1952	2SC1740S/QR/-T	SI. TRANSISTOR		*
Q1971-72	2SC1740S/QR/-T	SI. TRANSISTOR		*
Q1981	2SA949/Y/C1	SI. TRANSISTOR		*
Q1982	2SC1740S/QR/-T	SI. TRANSISTOR		*
I C				
IC1201	TB1226BN	I. C. (DIGI-OTHER)		
IC1203-05	LA7016	I. C. (MONO-ANA)		*
IC1421	LA7840	I. C. (MONO-ANA)		
IC1601	AN5265	I. C. (MONO-ANA)		*
IC1701	L78LR05E-MA	I. C. (MONO-ANA)		*
IC1731	M37212M6-121SP	MICON IC		
IC1732	AT24C04-10PC	I. C.		*
△ IC1921	STR-F6653	I. C. (HYBRID)		*
IC1951	K1A7812PI	I. C. (MONO-ANA)		*

△ Symbol No.	Part No.	Part Name	Description	Local
I C				
	IC1952	KIA7809PI	I. C. (MONO-ANA)	*
	IC1954	KIA7805PI	I. C. (MONO-ANA)	*
△	IC1971	S1854-C2	I. C. (MONO-ANA)	*
OTHERS				
	CM46978-A01-H	L. E. D. HOLDER		*
△	CP1951	ICP-N50-Y	I. C. PROTECT	*
△	CP1952	ICP-N75-Y	I. C. PROTECT	*
△	F1901	QMF51E2-3R15J4	FUSE	3. 15A
	FC1901-02	CEMG002-001Z	FUSE CLIP	*
	J1001-02	CEMB021-002	BNC CONNECTOR	*
	J1003	QMCC004-C01	MINI DIN JACK	*
	J1004	CEMN036-005	PIN JACK	*
	K1921	CE41433-001Z	BEADS CORE	*
	K1951-53	CE42050-001Z	CORE	*
△	LF1901	QQR0813-001	LINE FILTER	*
△	PC1921	TLP721F (D4-GR)	I. C. (PH. COUPLER)	*
	S1401	QSL4A13-C02	LEVER SWITCH	V. CENTER SW
	S1801	QSP1A11-C18Z	PUSH SWITCH	PHASE
	S1802	QSP1A11-C18Z	PUSH SWITCH	CHROMA
	S1803	QSP1A11-C18Z	PUSH SWITCH	BRIGHT
	S1804	QSP1A11-C18Z	PUSH SWITCH	CONTRAST
	S1805	QSP1A11-C18Z	PUSH SWITCH	MENU
	S1806	QSP1A11-C18Z	PUSH SWITCH	DOWN
	S1807	QSP1A11-C18Z	PUSH SWITCH	UP
	S1808	QSP1A11-C18Z	PUSH SWITCH	VIDEO. B
	S1809	QSP1A11-C18Z	PUSH SWITCH	VIDEO. A
△	S1901	QSP4K21-C01	PUSH SWITCH	POWER
△	SK1301	CE42554-001	CRT SOCKET	*
△	TH1901	QAD0101-9R0	P. THERMISTOR	*
	X1351	QAX0305-001Z	CRYSTAL	*
	X1731	CST8. 00MTW	CER. RESONATOR	*

PACKING

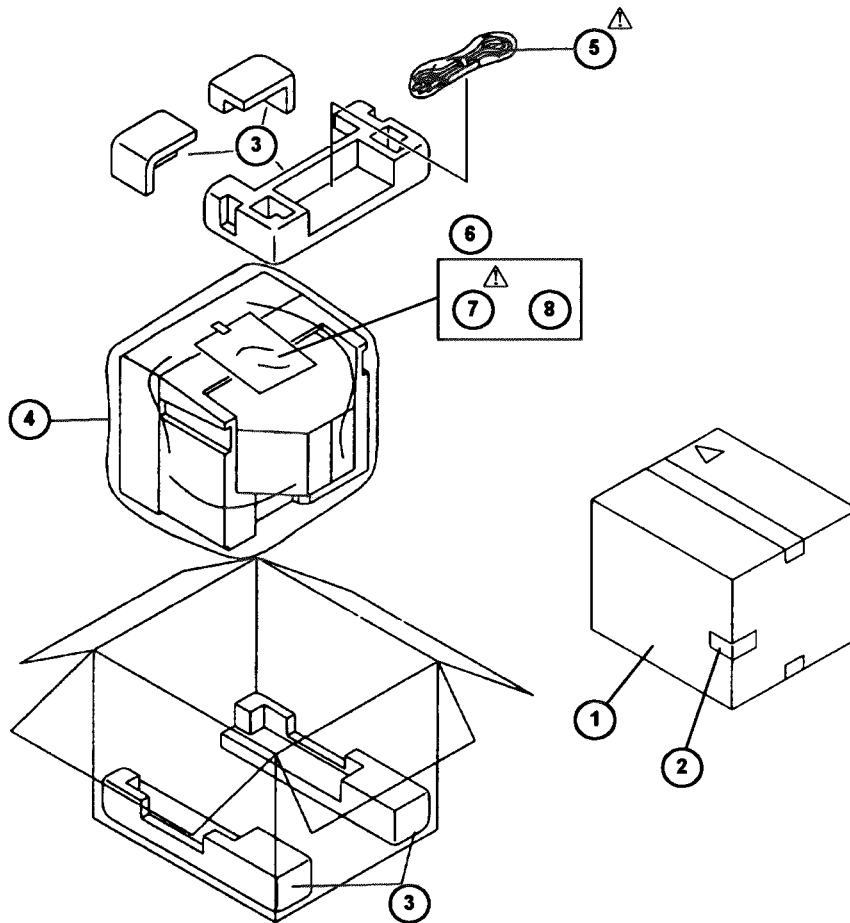

PACKING PARTS LIST

△ Ref. No.	Part No.	Part Name	Description	Local
1	AEM1002-053-E	PACKING CASE		*
2	AEM1038-071-E	EURO LABEL	[TM-A14PN]	*
2	AEM1038-072-E	EURO LABEL	[TM-A14PN-K]	*
3	LC10041-003A-U	CUSHION ASSY	5pcs in 1set	*
4	AEM1004-A01-E	POLY BAG		*
△ 5	QMPL040-200-JC	POWER CORD	[TM-A14PN]	*
△ 5	QMPP010-200-JC	POWER CORD	[TM-A14PN-K]	*
6	AEM3021-001-E	POLY BAG		*
△ 7	LCT0068-001A-U	INST BOOK	[TM-A14PN]	*
△ 7	LCT0069-001A-U	INST BOOK	[TM-A14PN-K]	*
8	LC20037-001A-U	X-RAY CARD	[TM-A14PN ONLY]	*

TM-A14PN
TM-A14PN-K

MEMO

MEMO

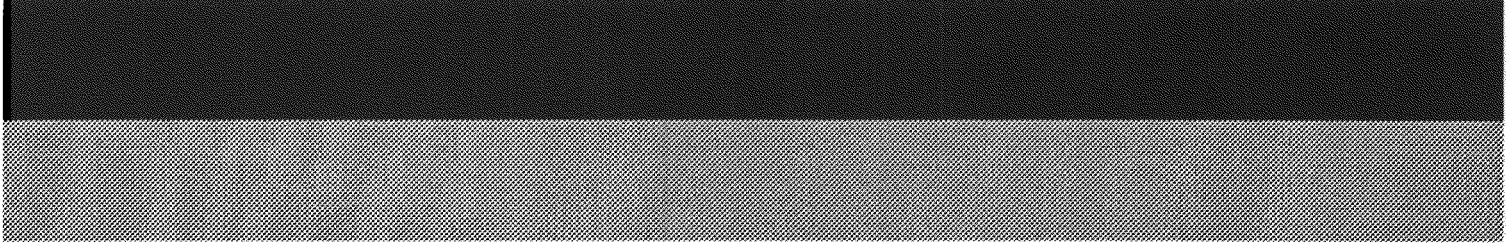

JVC

VICTOR COMPANY OF JAPAN, LIMITED

TELEVISION RECEIVER DIVISION 1106 Heta, Iwai-city, Ibaraki-prefecture, 306-06, Japan

TMA14PN-CKD #4
TMA14PNK-CKD #4



Printed in Japan
VP9801
DP2051